

# DENISON HYDRAULICS

*PV, PVT Series*

## piston pumps for open circuits

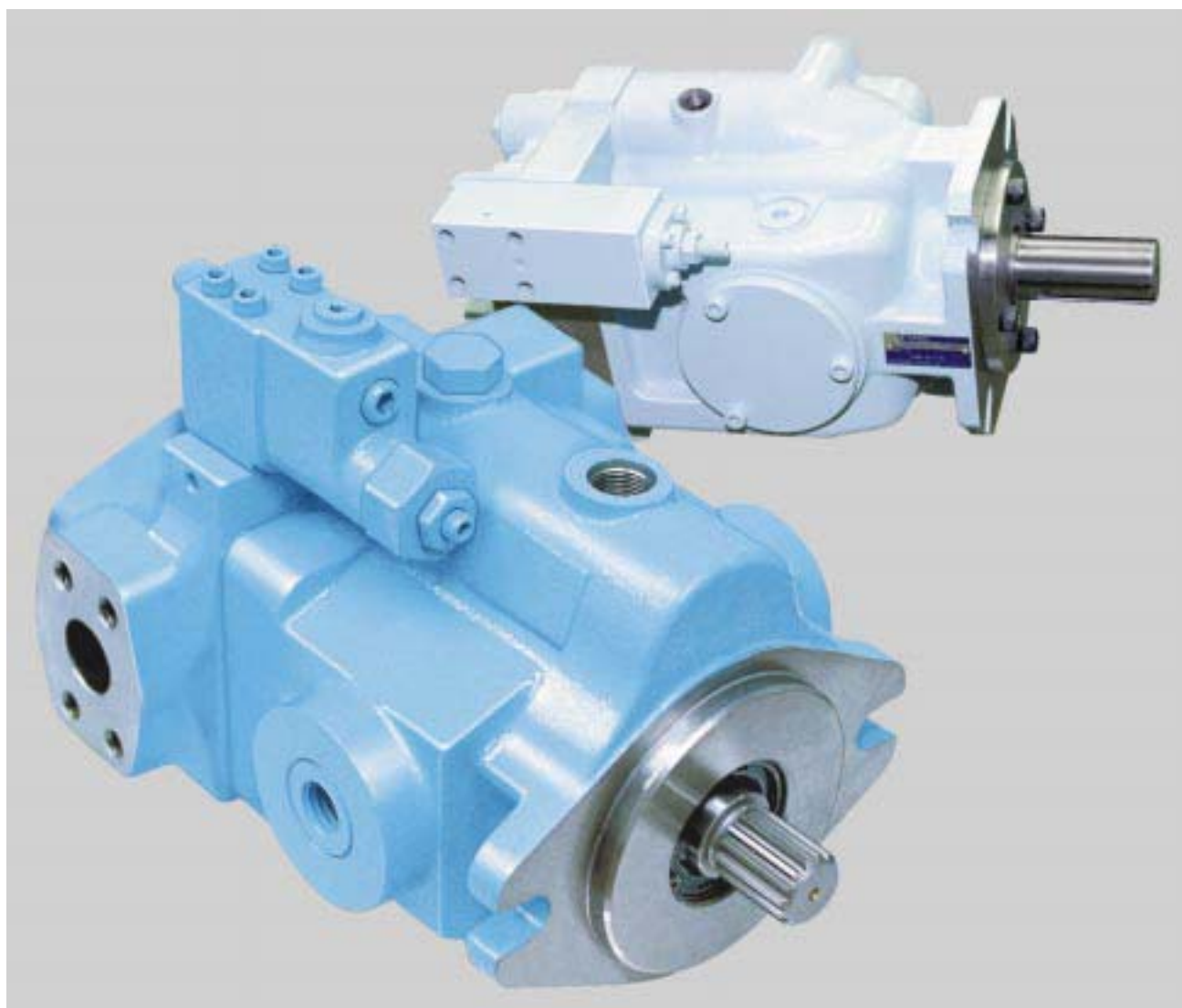

Publ. 1-AM0009 (replaces 1-AM009-E)

**DENISON** Hydraulics

E-Mail: [denison@denisonhydraulics.com](mailto:denison@denisonhydraulics.com) Internet: <http://www.denisonhydraulics.com>

## CONTENTS

	PAGE
data .....	.3
typical characteristics .....	.3
fluid connections .....	.4
maximum allowable through drive torque .....	.4
higher speed guide .....	.5
features .....	.6
benefits and features .....	.6
description .....	.7
general .....	.7
operation of pump .....	.7
rear drive .....	.7
shaft options .....	.7
input shaft information .....	.7
side load capability .....	.7
shaft bearing life .....	.7
piping .....	.7
service information .....	.8
recommended fluids .....	.8
viscosity .....	.8
viscosity index .....	.8
temperature .....	.8
maintenance .....	.8
fluid cleanliness .....	.8
comparison of solid contamination classification system .....	.8
system relief valves .....	.9
compensators .....	.9-10
installations .....	.11
PV6 .....	.11
PV10 .....	.12
PV15 .....	.13
PV20/PVM 20 .....	.14
PV29 .....	.15
PVT6 .....	.16
PVT10 .....	.17
PVT15 .....	.18
PVT20/PVR 20 .....	.19
PVT29 .....	.20
PVT38 .....	.21
PVT47 .....	.22
PVT64 .....	.23
PV torque limiters .....	.24
F and L compensators .....	.25
PVT38, 47, 64 rear drives .....	.26-28
SAE - A and SAE - B .....	.26
SAE - BB and SAE - C .....	.27
SAE - CC and SAE - D .....	.28
performance curves .....	.29
at 1800 .....	.29-30
at 1500 .....	.31-32
ordering code .....	.33
conversions & formulas .....	.34

## DATA

### TYPICAL CHARACTERISTICS

Specification	Term	Series PV6 PVT6	Series PV10 PVT10	Series PV15 PVT15	Series PV20 PVT20	Series PVM20 PVR20	Series PV29 PVT29	Series PVT38	Series PVT47	Series PVT64
•displacement at max angle	in <sup>3</sup> /rev. cm <sup>3</sup> /rev.	0.88 14.4	1.26 20.6	2.09 34.2	2.62 42.9	2.62 42.9	3.78 61.9	4.88 80.0	6.10 100.0	7.93 130.0
•pressure, continuous	psi bar	3500 240	3500 240	3500 240	3500 240	3500 240	3000 207	4000 280	4000 280	4000 280
intermittent <sup>1)</sup>	psi bar	4500 310	4500 310	4500 310	4500 310	4500 310	4000 280	4350 300	4350 300	4350 300
•speed, max. <sup>2)</sup>	rpm	3000	3000	2500	2400	2600	2400	1800	1800	1800
•rotating inertia	lb in <sup>2</sup> kg m <sup>2</sup>	2.00 .0006	3.3 .00099	7.87 .00233	11.97 .00355	11.97 .00355	21.84 .00647	27.98 .00829	44.39 .01315	68.22 .02021
•compensator response off-stroke on-stroke	ms ms	50 120	50 120	50 120	50 120	50 120	50 120	50 100	50 100	50 100
•compensator range	psi bar	130-4000 9-276	130-4000 9-276	130-4000 9-276	130-4000 9-276	130-4000 9-276	130-3500 9-241	215-4000 15-280	215-4000 15-280	215-4000 15-280
•compensator- adjustment	psi/turn bar/turn	650 44.8	650 44.8	650 44.8	650 44.8	650 44.8	650 44.8	650 44.8	650 44.8	650 44.8
•max. vol. adjustment full to zero- stroke maximum torque <sup>3)</sup>	turns lb-in Nm	8.5 28 3.2	8.5 25 2.8	8.5 41 4.6	9.7 49 5.5	9.7 49 5.5	10.5 45 5.1	13.1	14.0	15.3
•minimum inlet- at 1800 rpm	in-Hg mm-Hg	-6.1 -155	-6.1 -155	-6.1 -155	-6.1 -155	-6.1 -155	-6.1 -155	-4.9 -125	-4.9 -125	-4.9 -125
•maximum inlet- pressure	psi bar	50 3.4	50 3.4	50 3.4	50 3.4	50 3.4	50 3.4	50 3.5	50 3.5	50 3.5
•max. case pressure	psi bar	10 0.7	10 0.7	10 0.7	10 0.7	10 0.7	10 0.7	7 0.5	7 0.5	7 0.5
•peak case pressure- over inlet pressure	psi bar	15 1	15 1	15 1	15 1	15 1	15 1	7 0.5	7 0.5	7 0.5
•input mounting	SAE	82-2 (A)	101-2 (B)	101-2 (B)	127-2 (C)	127-2 (C)	127-2 (C)	127-4 (C)	127-4 (C)	152-4 (D)
•input shaft, keyed splined	SAE	19-1 22-4 (A)(B)	22-1 22-4 (B)	22,25-1 <sup>4)</sup> 22,25-4 <sup>4)</sup> (B,B-B)	32-1 32-4 (C)	32-1 32-4 (C)	32-1 32-4 (C)	38-1 38-4 (CC)	44-1 38-4 (D,CC)	44-1 44-4 (D)
•shaft bearing life at- 1800 rpm, 2500 psi (*4000 psi)	hrs	3100	4800	3500	4400	4400	2100	8776	13789	24720
front bearing	hrs	9600	9400	3100	5100	5100	2600	7165	11510	15533
rear bearing	hrs									
1500 rpm, 172 bar (*280 bar)	hrs	3720	5760	4200	5280	5280	2520	10531	16547	29964
front bearing	hrs	11520	11280	3720	6120	6120	3120	8598	13812	18640
rear bearing	hrs									
•weight-approx. -PV, PVM	lb Kg	24 11	36 16	43 20	57 26	57 26	73 33	— —	— —	— —
•weight-approx. -PVT, PVR	lb Kg	30 14	45 20	55 25	71 32	71 32	93 42	110 50	156 71	211 95

<sup>1)</sup> 10% of operation time, not exceeding 6 successive seconds.

<sup>2)</sup> for speeds over 1800 rpm see higher speeds guideline chart pg. 5.

<sup>3)</sup> this is a maximum torque-actual torque reduces by about 25% at full stroke.

<sup>4)</sup> PV15 uses 22-1,22-4 (SAE-B) only

\* PVT 38, 47 and 64

**DATA**

**FLUID CONNECTIONS**

	Term	Series PV6	Series PV10	Series PV15	Series PV20	Series PVM20	Series PV29	Series PVT38	Series PVT47	Series PVT64
•port A PV/PVM (inlet)	SAE St. Thd.	-12	-20	-20	-20	-24	-20	N/A	N/A	N/A
	BSP	3/4	1-1/4	1-1/4	1-1/4	1-1/2	1-1/4	N/A	N/A	N/A
•port B PV/PVM (outlet)	SAE St. Thd.	-12	-20	-20	-20	-20	-20	N/A	N/A	N/A
	BSP	3/4	1-1/4	1-1/4	1-1/4	1-1/4	1-1/4	N/A	N/A	N/A
•port A (inlet),PVT/PVR SAE code 61 4 bolt fig.	in.	1"	1.25"	1.5"	1.5"	1.5"	2"	2"	2.5"	2.5"
	mm	25.4	31.75	38.1	38.1	38.1	50.8	50.0	63.5	63.5
•port B (outlet),PVT/PVR SAE code 61 4 bolt fig.	in.	.75"	1"	1"	1"	1"	1"	1.5"	1.5"	1.5"
	mm	19.1	25.4	25.4	25.4	25.4	25.4	38.1	38.1	38.1
•port D	SAE St. Thd.	-6	-8	-8	-8	-8	-8	-12	-12	-12
	BSP	3/8	1/2	1/2	1/2	1/2	1/2	N/A	N/A	N/A
•port V	SAE St. Thd.	-4	-4	-4	-4	-4	-4	-4	-4	-4
	BSP	1/4	1/4	1/4	1/4	1/4	1/4	N/A	N/A	N/A

**MAXIMUM ALLOWABLE THROUGH DRIVE TORQUE**

**Max. input torque:** max. torque allowed on input shaft from the combined torques of front and rear pumps.  
**Max. rear drive torque:** max. torque allowed from rear pump.

	input shaft	max. input torque lbs-in.(Nm)	rear mounting pad	rear drive coupling (spline)	max. rear drive torque lbs-in.(Nm)
<b>PVT6</b>	SAE-19-1 (A) key	1125 (127,1)	SAE-82-2 (A)	SAE-16-4 (A)	1125 (127,1)
	SAE-22-4 (B) spline	2025 (228,8)		SAE-22-4 (B)	1125 (127,1)
<b>PVT10</b>	SAE-22-1 (B) key	1680 (189,8)	SAE-82-2,101-2 (A,B)	SAE-16-4 (A)	1680 (189,8)
	SAE-22-4 (B) spline	2550 (288,1)		SAE-22-4 (B)	1925 (217,5)
<b>PVT15</b>	SAE-22-1 (B) key	1680 (189,8)	SAE-82-2,101-2 (A,B)	SAE-16-4 (A)	1680 (189,8)
	SAE-22-4 (B) spline	2185 (246,9)		SAE-22-4 (B)	2000 (226)
	SAE-25-1 (B-B) key	2850 (332)		SAE-25-4 (B-B)	2000 (226)
	SAE-25-4 (B-B) spline	3825 (432,2)			2000 (226)
<b>PVT20 PVR20</b>	SAE-32-1 (C) key	4675 (528,3)	SAE-82-2,101-2,127-2 (A,B,C)	SAE-16-4 (A)	3850 (435)
	SAE-32-4 (C) spline	4675 (528,3)		SAE-22-4 (B)	3850 (435)
<b>PVT29</b>	SAE-32-1 (C) key SAE-32-4 (C) spline	4880 (551,4) 6300 (711,9)	SAE-82-2,101-2,127-2 (A,B,C)	SAE-16-4 (A)	3850 (435)
				SAE-22-4 (B)	3850 (435)
				SAE-25-4 (B-B)	
				SAE-32-4 (C)	
<b>PVT38</b>	SAE-38-4 (CC) spline SAE-38-2 (CC) key	6501 (735) 6501 (735)	SAE-82-2, 101-2,127-2 (A,B,C)	SAE-16-4 (A)	3007 (340)
				SAE-22-4 (B)	
				SAE-25-4 (B-B)	
				SAE-32-4 (C)	
<b>PVT47</b>	SAE-38-4 (CC) spline SAE-44-2 (D) key	8756 (990) 8756 (990)	SAE-82-2,101-2,127-2 (A,B,C)	SAE-16-4 (A)	5660 (640)
				SAE-22-4 (B)	
				SAE-25-4 (B-B)	
				SAE-32-4 (C)	
<b>PVT64</b>	SAE-38-4 (D) spline SAE-44-2 (D) key	11365 (1285) 11365 (1285)	SAE-82-2, 101-2, 127-2, 127-4, 152-4 (A,B,C,D)	SAE-16-4 (A)	5660 (640)
				SAE-22-4 (B)	
				SAE-25-4 (B-B)	
				SAE-32-4 (C)	
				SAE-38-4 (C-C)	
				SAE-44-4 (D)	

**DATA**

**HIGHER SPEED GUIDES**

	Speed rpm	Minimum inlet pressure				maximum case pressure	
		pressure gage		absolute pressure		psi	bar
		psi	bar	psi	bar		
<b>PV6 PVT6</b>	1800	-3.0	-0,2	11.7	0,8	10	0,7
	2050	-3.0	-0,2	11.7	0,8	7	0,5
	2100	-3.0	-0,2	11.7	0,8	5	0,3
	2750	-2.4	-0,2	12.4	0,9	5	0,3
	2900	-1.0	-0,1	13.7	1,0	5	0,3
	3000	0.0	0,0	14.7	1,0	5	0,3
<b>PV10 PVT10</b>	1800	-3.0	-0,2	11.7	0,8	10	0,7
	2100	-3.0	-0,2	11.7	0,8	7	0,5
	2500	-3.0	-0,2	11.7	0,8	5	0,3
	2550	-2.5	-0,2	12.2	0,8	5	0,3
	2700	-1.0	-0,1	13.7	0,9	5	0,3
	2800	0.0	0,0	14.7	1,0	5	0,3
	3000	2.2	0,2	16.9	1,2	5	0,3
<b>PV15 PVT15</b>	1800	-3.0	-0,2	11.7	0,8	10	0,7
	2100	-3.0	-0,2	11.7	0,8	7	0,5
	2230	-3.0	-0,2	11.7	0,8	5	0,3
	2275	-2.5	-0,2	12.2	0,8	5	0,3
	2350	-1.7	-0,1	13.0	0,9	5	0,3
	2500	0.0	0,0	14.7	1,0	5	0,3
<b>PV20 PVT20</b>	1800	-3.0	-0,2	11.7	0,8	10	0,7
	2050	-3.0	-0,2	11.7	0,8	7	0,5
	2100	-2.5	-0,2	12.3	0,9	5	0,3
	2200	-1.3	-0,1	13.5	0,9	5	0,3
	2300	-0.0	-0,0	14.7	1,0	5	0,3
	2400	1.3	0,1	16.0	1,1	5	0,3
<b>PVM20 PVR20</b>	1800	-3.0	-0,2	11.7	0,8	10	0,7
	2000	-3.0	-0,2	11.7	0,8	7	0,5
	2100	-3.0	-0,2	11.7	0,8	5	0,3
	2200	-2.0	-0,1	12.7	0,9	5	0,3
	2400	-1.0	-0,1	13.7	0,9	5	0,3
	2600	0.0	0,0	14.7	1,0	5	0,3
<b>PV29 PVT29</b>	1800	-3.0	-0,2	11.7	0,8	10	0,7
	2050	-3.0	-0,2	11.7	0,8	7	0,5
	2100	-2.5	-0,2	12.3	0,9	5	0,3
	2200	-1.3	-0,1	13.5	0,9	5	0,3
	2300	-0.0	-0,0	14.7	1,0	5	0,3
	2400	1.3	0,1	16.0	1,1	5	0,3
<b>PVT38</b>	1800	-2.0	-0,15	14.1	0,95	7	0,5
<b>PVT47</b>	1800	-2.0	-0,15	14.1	0,95	7	0,5
<b>PVT64</b>	1800	-2.0	-0,15	14.1	0,95	7	0,5

Note: Watch the case pressures carefully. Rapid compensation at high speeds can cause severe case spikes. If the pump feeds into a blocked center valve that closes quickly, use both case drain ports and direct short case drain lines and a relief valve.

## FEATURES

### Benefits and features:

For quiet operation and high productivity, specify DENISON'S PV and PVT series pressure compensated, variable volume axial piston pumps. Designed right and built tough, they provide reliable fluid power...even under severe conditions!

You gain more efficient machine operation, upgrade equipment performance and reduce maintenance easily with these quiet, efficient pumps. Because they are interchangeable with other popular pumps, you can use the PV pumps to replace existing older pumps which are not functioning to your satisfaction.

### Check these benefits:

- **quiet operation**- improves working conditions, low noise levels over entire operating range.
- **contamination tolerances**- improves dependability and reduces maintenance cost.
- **more power**- because of the PV's high pressure ratings. Max. intermittent operating pressures to 4500 psi (310) bar.
- **system savings**- because higher pressure allows use of smaller components...you can "downsize" and gain real savings.
- **versatility**- full power through drive to allow multiple pumps to be driven from one prime mover.
- **convenience**- side or rear port options for ease and convenience of mounting.
- **high productivity**- because of unique efficiency.
- **greater safety**- you can use fire resistant hydraulic fluids without sacrificing performance.
- **simple construction**- for long, dependable service.
- **tailor the flow**- to your needs with the standard maximum volume adjustment.
- **interchangeable**- with other SAE mounted piston pumps. Conformance to SAE flange mounting and SAE, BSPP or SAE code 61 4-bolt flange.

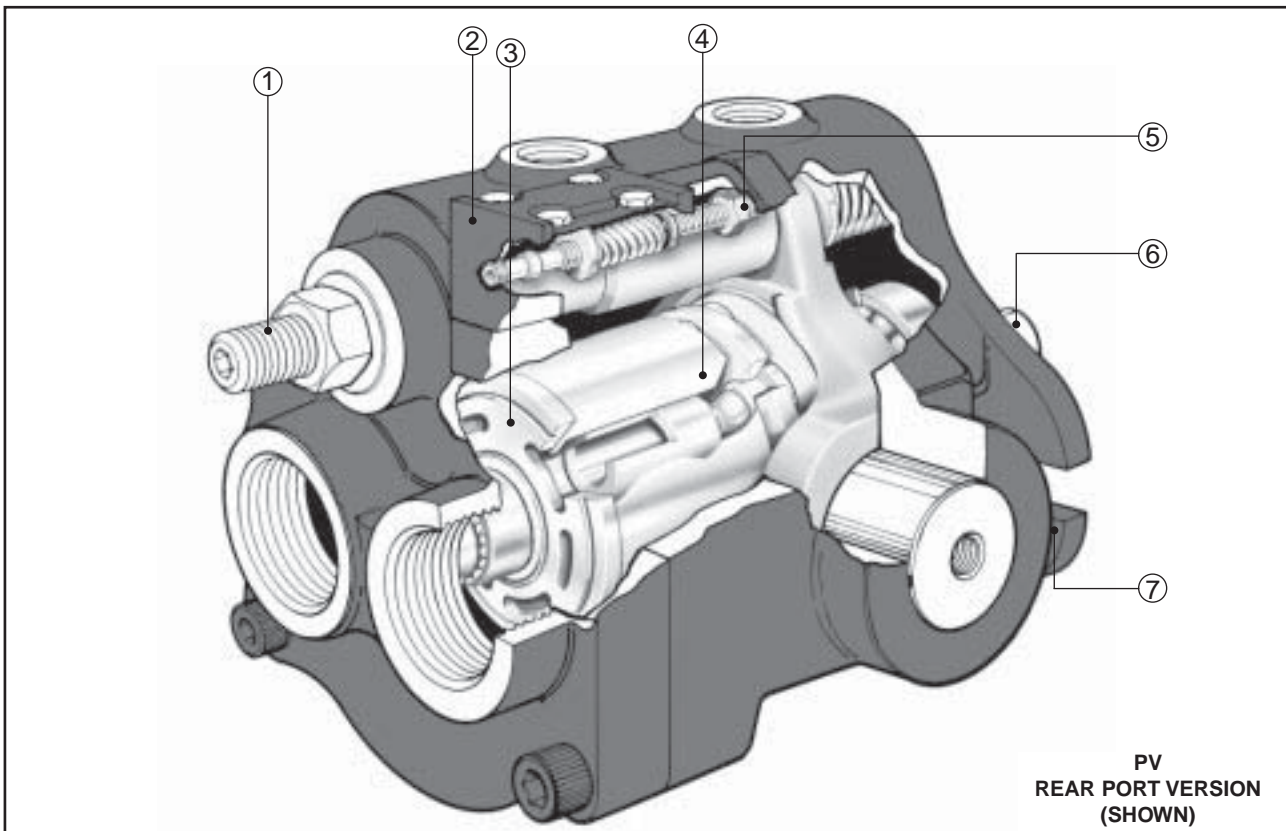

1 **maximum volume adjustment**

2 **fast compensator response**- 50 ms. off-stroke, 120 ms on-stroke. Other controls available- ventable compensator, load sensing and power limiter

3 **port plate**- replaceable

4 **smoother power and quieter operation**- with nine-piston rotating group

5 **adjustable compensator**

6 **key and spline conform** to industry standard

7 **SAE mounting**- easily interchangeable with other SAE mounted pumps

- **operates with many hydraulic fluids**
- **also available are side porting and rear drive**

## DESCRIPTION

### GENERAL

The PV/PVT series pumps are variable displacement open circuit piston pumps with a design emphasis on operation economy. These axial piston pumps for open loop operation are suitable for rear drive in the PVT series configuration.

The PV/PVT pumps have a displacement of 0.88 to 7.93 cu. in/rev. (14,4 to 130,0 cc/rev.) with a continuous working pressure up to 4000 psi (280 bar): The pumps can be equipped with a pressure compensator, ventable compensator, load sensing or power limit control.

### MOUNTING

The PV/PVT pumps have been designed to operate in a wide range of applications in industries where high pressure and variable flow are required at competitive cost.

These pumps are designed to operate in any position. The mounting hub and two bolt mounting flange are in conformance with SAE standards. The pump shaft must be in alignment with the shaft of the source driver and should be checked with a dial indicator. The mating pilot bore and coupling must be concentric. This concentricity is particularly important if the shaft is rigidly connected to the driven load without a flexible coupling.

### REAR DRIVE:

See installation drawings page 11 thru 23 of this bulletin for mounting and page 24 for **maximum allowable torque** in the data section for torque limits.

### SHAFT OPTIONS:

SAE splined and keyed, see installation drawings page 11 thru 23 for details.

### INPUT SHAFT INFORMATION:

**Splined:** The shafts will accept a maximum misalignment of 0.002 in. (0,06mm) total indicator reading when the pump is foot mounted and 0.001 in. (0,03 mm) when flange mounted. Angular misalignment at the male and female spline axis must be less than  $\pm 0,002$  inch per inch radius ( $\pm 0,002$  mm/mm). The coupling interface must be lubricated.

DENISON recommends lithium molydisulfide or similar grease. The female coupling should be hardened to 27/34 Rc and must conform to SAE-J498c, class 5 flat root side fit.

**Keyed:** High strength heat treated keys must be used. Replacement keys must be hardened to 27-34 Rc. The key corners must be chamfered 0.03 - 0.04 in. (0,75-1,0 mm) at 45° to clear radii that exist in the keyway.

### SIDE LOAD CAPABILITY:

The PV series is designed for inline-drive and side loading on the shaft is not recommended. If this is unavoidable consult your nearest DENISON HYDRAULICS representative.

### SHAFT BEARING LIFE:

See chart in data section of this bulletin.

See installation drawings in the back of this bulletin for port connections.

### PIPING

The maximum case pressure is shown on page 3. Case pressure must never exceed inlet pressure by more than 13 psi (0,9 bar). When connecting case drain line make certain that drain plumbing passes above highest point of the pump before passing to the reservoir.

The case leakage line must be of sufficient size to prevent back pressure in excess of the values on page 3 and returned to the reservoir below the surface of the oil as far from the supply suction as possible. All fluid lines, whether pipe, tubing, or hose must be adequate size and strength to assure free flow through the pump. An undersize inlet line will prevent the pump from operating at full rated speed. An undersize outlet line will create back pressure and cause heat generation. Flexible hose lines are recommended. If rigid piping is used, the workmanship must be accurate to eliminate strain on the pump port block or to the fluid connections. Sharp bends in the lines must be eliminated wherever possible. All system piping must be cleaned with solvent or equivalent before installing pump. Make sure the entire hydraulic system is free of dirt, lint, scale, or other foreign material.

**Caution:** Do not use galvanized pipe. Galvanized coating can flake off with continued use.



## DESCRIPTION

### SERVICE INFORMATION

These hydraulic products are designed to give long dependable service when properly applied and their systems properly maintained. These general instructions apply to typical systems. Specific instructions for particular equipment can be developed from them.

**Refer to bulletin S1-AM009 for service information.**

### RECOMMENDED FLUIDS

The fluid recommended for use in these pumps has a petroleum base and contains agents which provide oxidation inhibition and anti-rust, anti-foam and de-aerating properties as described in DENISON HYDRAULICS standard HF-1. Where anti-wear additive fluids are specified, see DENISON HYDRAULICS standard HF-0.

### VISCOSITY

max. at cold start- 7500 SUS (1600 cSt)  
 at low pressure, low flow, and if possible, low speed  
 max. at full power- 750 SUS (160 cSt)  
 optimum for max. life- 140 SUS (30 cSt)  
 minimum at full power- 60 SUS (10 cSt)

### VISCOSITY INDEX

90 V. I. minimum. Higher values extend the range of operating temperature but may reduce the service life of the fluid.

### TEMPERATURE

Determined by the viscosity characteristics of the fluid used. Because high temperatures degrade seals, reduce the service life of the fluid and create hazards, fluid temperature should not exceed 180° F (82° C) at the case drain.

### MAINTENANCE

The pump is self-lubricating and preventative maintenance is limited to keeping system fluid clean by changing filters frequently. Keep all fittings and screws tight. Do not operate at pressures and speeds in excess of the recommended limit. If the pump does not operate properly, check the troubleshooting chart before attempting to overhaul the unit. Overhauling may be accomplished by referring to the disassembly, rework limits of wear parts, and assembly procedures. Refer to the service manual for troubleshooting and overhaul information.

### FLUID CLEANLINESS

Fluid must be cleaned before and continuously during operation by filters that maintain a cleanliness level of ISO 17/14. This approximately corresponds to NAS 1638 class 8 (class 9 for 15 micron and smaller). This fluid level cleanliness can usually be accomplished by the effective use of 10 micron filters. Better cleanliness levels will significantly extend the life of the components. As contaminant generation may vary with each application, each must be analyzed to determine proper filtration to maintain the required cleanliness level.

## COMPARISON OF SOLID CONTAMINATION CLASSIFICATION SYSTEM

### NATIONAL AERONAUTICS STANDARD (NAS) 1638

		class													
		00	0	1	2	3	4	5	6	7	8	9	10	11	12
particle size range	5-15µm	125	250	500	1000	2000	4000	8000	16000	32000	64000	128000	256000	512000	1024000
	15-25µm	22	44	89	178	356	712	1425	2850	5700	11400	22800	45600	91200	182400
	25-50µm	4	8	16	32	63	126	253	506	1012	2025	4050	8100	16200	32400
	50-100µm	1	2	3	6	11	22	45	90	180	360	720	1440	2880	5760
	>100µm	0	0	1	1	2	4	8	16	32	64	128	256	512	1024
maximum particles	>5µm	152	304	609	1217	2432	4864	9731	19462	38924	77849	155698	311396	622792	1245584
	>15µm	27	54	109	217	432	864	1731	3462	6924	13849	27698	55396	110792	221584

### ISO:DIS 4406; SAE J1165

		iso solid contaminant code														
		8/5	9/6	10/7	11/8	12/9	13/10	14/11	15/12	16/13	17/14	18/15	19/16	20/17	21/18	22/19
maximum	>5µm	250	500	1000	2000	4000	8000	16000	32000	64000	130000	250000	500000	1000000	2000000	4000000
particles	>15µm	32	64	130	250	500	1000	2000	4000	8000	16000	32000	64000	130000	250000	500000

NOTES: All measurements are for a 100 ml sample size.



## DESCRIPTION

### SYSTEM RELIEF VALVES

Although the PV/PVT series pumps have very fast off-stroke compensator response, system relief valves are recommended in all cases for safety considerations.

### COMPENSATOR

The C and F pressure compensator control allows the pump to deliver full volume from the outlet port until the pressure rises to the value set by the control. One turn clockwise of the pressure compensator adjusting screw represents a pressure increase of approximately 650 psi (45 bar).

The control then reduces the pump volume to that required by the system while maintaining the preset pressure at the outlet port. The stroking piston is controlled by a 3-way valve which is shifted by discharge pressure.

The fast response (typically 50 ms off-stroke and 120 ms on-stroke) and high flow capacity of this valve holds pressure overshoot and undershoot to a minimum.

An adjusting screw complete with locknut allows the pump volume to be set between maximum and zero.

Clockwise rotation pumps have the pressure compensator control located on the left side of the pump body; on counter clockwise rotation pumps the control is on the right side.

Units with C- compensator, a 30-50 psi (2-3 bar) check valve is recommended in the discharge port on all open loop pumps. The check valve must be located approximately 12 in. (0.3 M) from the discharge port. Failure to locate the check valve at this point may result in compensator hunting.

### C- COMPENSATOR CIRCUIT

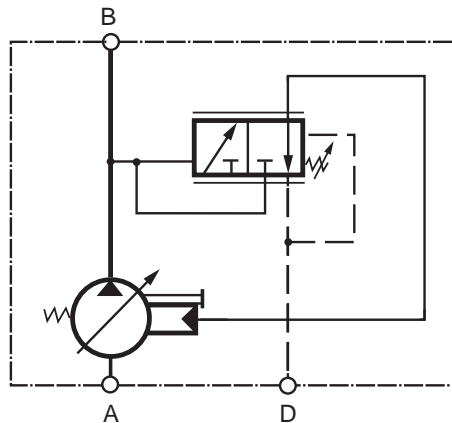

A – Inlet  
B – Outlet  
D – Case drain

### F- VENTABLE COMPENSATOR

The F- compensator is used in applications requiring remote control pressure. The remote relief is connected to the vent port. The pressure may be controlled at any level below the compensator pressure setting. The vent port may also be used to remotely vent-off the compensator for starting.

**Caution:** The F- and L- differential spring is the same as the C- compensator spring. Therefore it is possible to set the differential pressure too high.

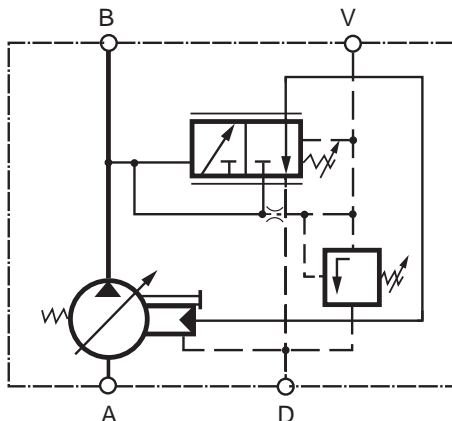

A – Inlet  
B – Outlet  
D – Case drain  
V – Vent

## DESCRIPTION

### L- LOAD SENSING COMPENSATOR

The L- compensator is used for load sensing circuits. The L- compensator prevents pilot flow from entering the circuit which will eliminate creeping of the load. The L- compensator will let the pump deliver a constant flow rate to the circuit by providing an adjustable  $\Delta P$  across the customer's orifice or valve. The pump will operate at 250-400 psi (17-28 bar) above load pressure.

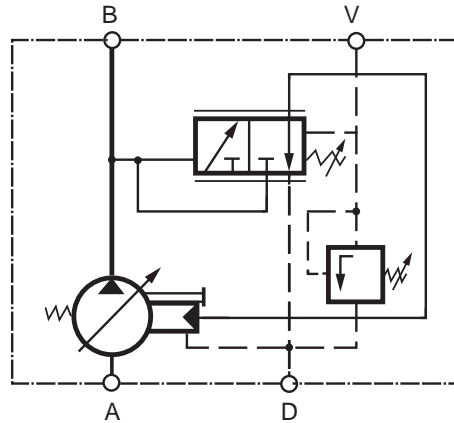

A – Inlet  
 B – Outlet  
 D – Case drain  
 V – Vent

### J- TORQUE LIMITER (low range) K- TORQUE LIMITER (high range)

The torque limiter monitors both pressure and displacement (hanger angle). It is a single spring unit which works with the "F" compensator, and can also be connected into a load sensing or remote venting circuit. As pressure rises, flow is reduced according to the zero adjustment and spring rate of the torque limiter. When pressure has risen to its full value, control is assumed by the "F" compensator. The torque limiter functions down to 20% of corner power. Lower adjustments are possible, at the expense of peak pressure.

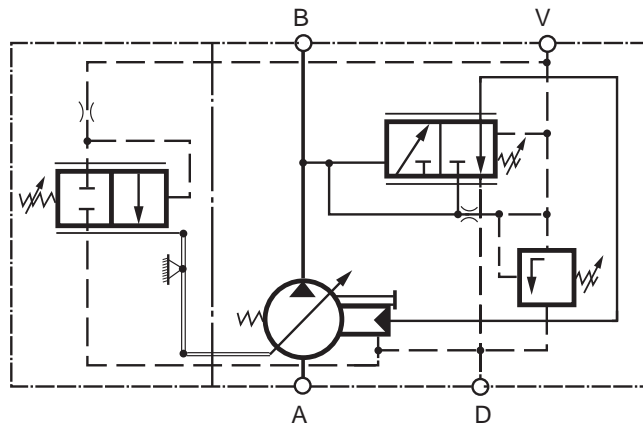

A – Inlet  
 B – Outlet  
 D – Case drain  
 V – Vent

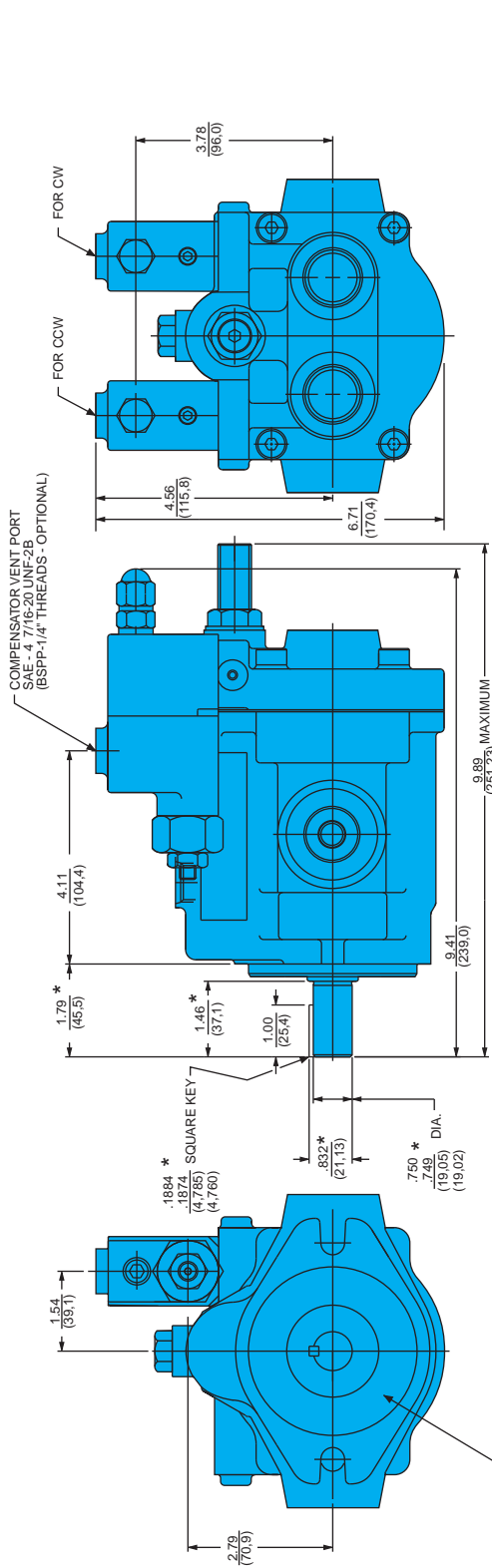

"F" AND "L" COMPENSATOR - KEYED SHAFT  
(SPLINED SHAFT SHOWN BELOW)

NOTE:  
TWO BOLT MOUNTING FLANGE CONFORMS TO SAE 82-2 (SAE A) SPECIFICATIONS  
EXCEPT FOR DIMENSIONS MARKED WITH AN ASTERISK \*.

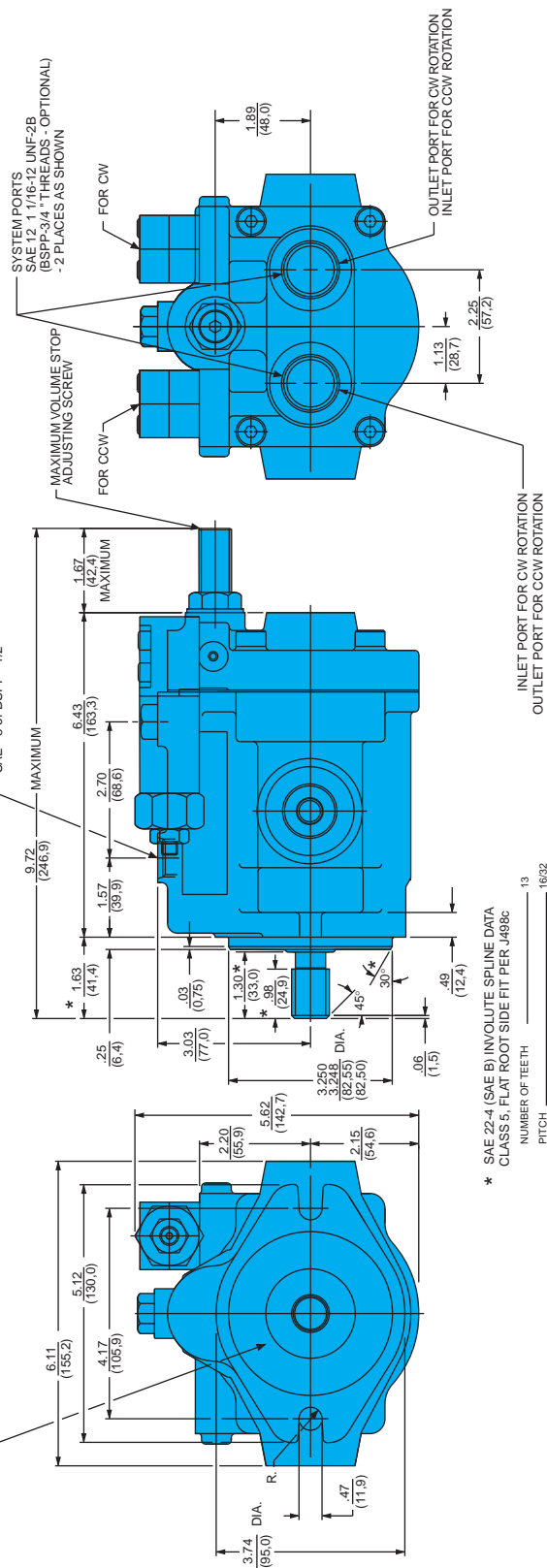

"C" COMPENSATOR - SPLINED SHAFT  
(KEYED SHAFT SHOWN ABOVE)

"D" Series PV6

\* SAE 22-4 (SAE B) INVOLUTE SPLINE DATA  
CLASS 5, FLAT ROOT SIDE FIT PER J488c

NUMBER OF TEETH 13

PITCH 16/32

PRESSURE ANGLE 30°

MAJOR DIA. .875/.853 (22.23/21.87)

MINOR DIA. .715 (18.16)

NOTE: DIMENSIONS IN PARENTHESIS ARE METRIC (SI UNITS).

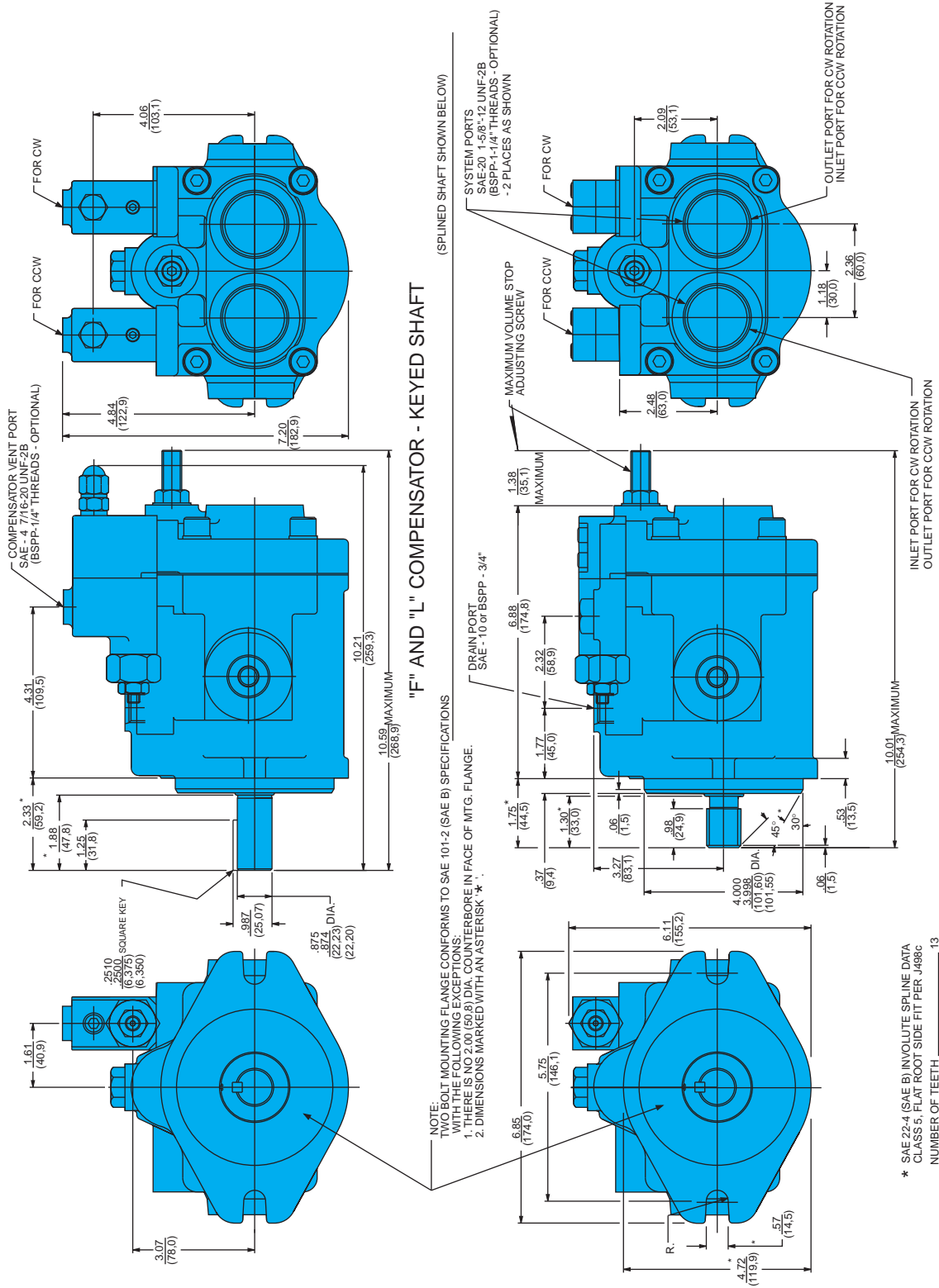

**"C" COMPENSATOR - SPLINED SHAFT**  
(KEYED SHAFT SHOWN ABOVE)

NOTE: DIMENSIONS IN PARENTHESIS ARE METRIC (SI UNITS).

- \* SAE 22-4 (SAE B) INVOLUTE SPLINE DATA CLASS 5, FLAT ROOT SIDE FIT PER J498c
- NUMBER OF TEETH \_\_\_\_\_ 13
- PITCH \_\_\_\_\_ 16/32
- PRESSURE ANGLE \_\_\_\_\_ 30°
- MAJOR DIA. \_\_\_\_\_ .875/.863 (22.23/21.67)
- MINOR DIA. \_\_\_\_\_ .715 (18.16)

"D" Series PV10



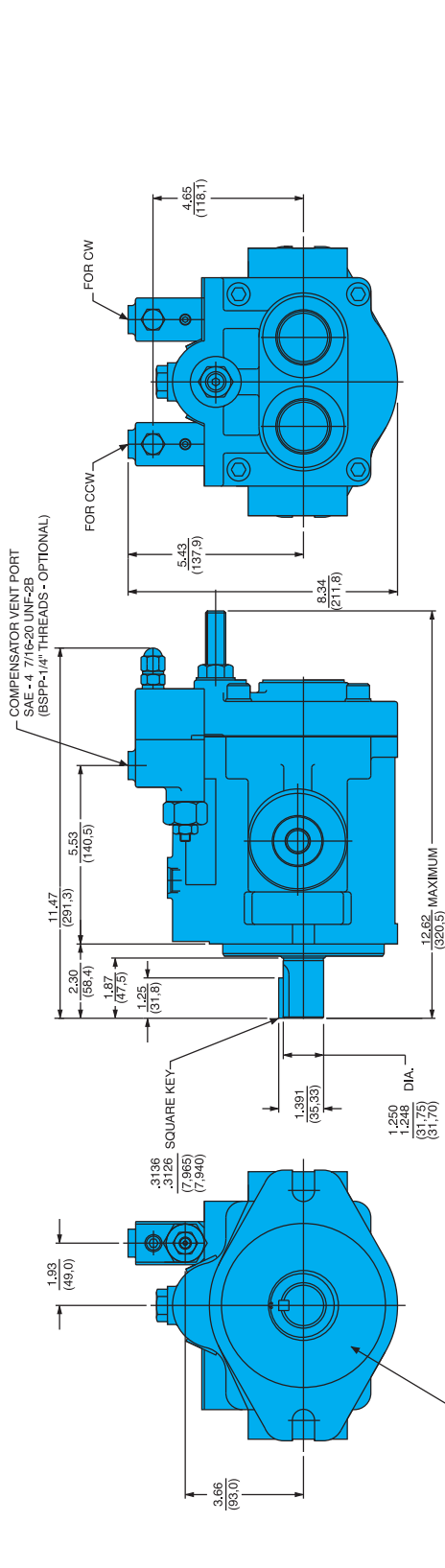

"F" AND "L" COMPENSATOR - KEYED SHAFT  
(SPLINED SHAFT SHOWN BELOW)

NOTE:  
TWO BOLT MOUNTING FLANGE CONFORMS TO SAE 127-2 (SAE C) SPECIFICATIONS  
WITH THE FOLLOWING EXCEPTIONS:  
1. THERE IS NO 2.50 (63.5) DIA. COUNTERBORE IN FACE OF MTG. FLANGE.  
2. DIMENSIONS MARKED WITH AN ASTERISK \*.

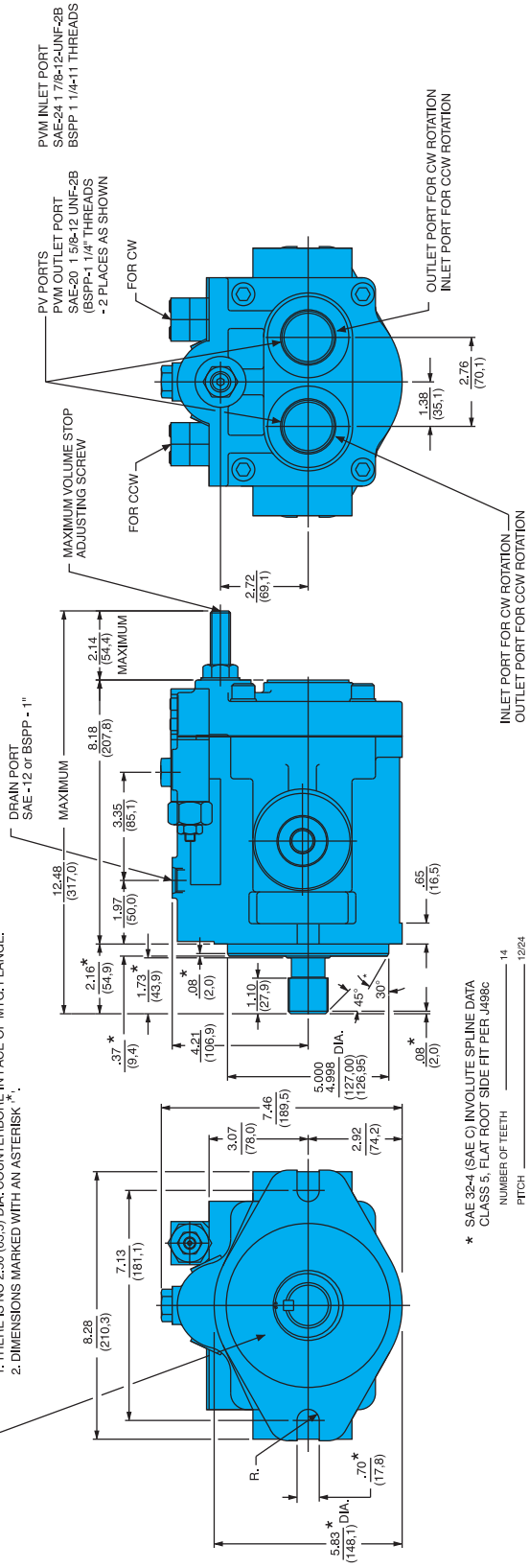

"C" COMPENSATOR - SPLINED SHAFT  
(KEYED SHAFT SHOWN ABOVE)

"D" Series PV20

\* SAE 32-4 (SAE C) INVOLUTE SPLINE DATA  
CLASS 5, FLAT ROOT SIDE FIT PER J498C

NUMBER OF TEETH	14
PITCH	12/24
PRESSURE ANGLE	30°
MAJOR DIA.	1.250 (31.75)
MINOR DIA.	1.040 (26.4)

NOTE: DIMENSIONS IN PARENTHESIS ARE METRIC (SI UNITS).

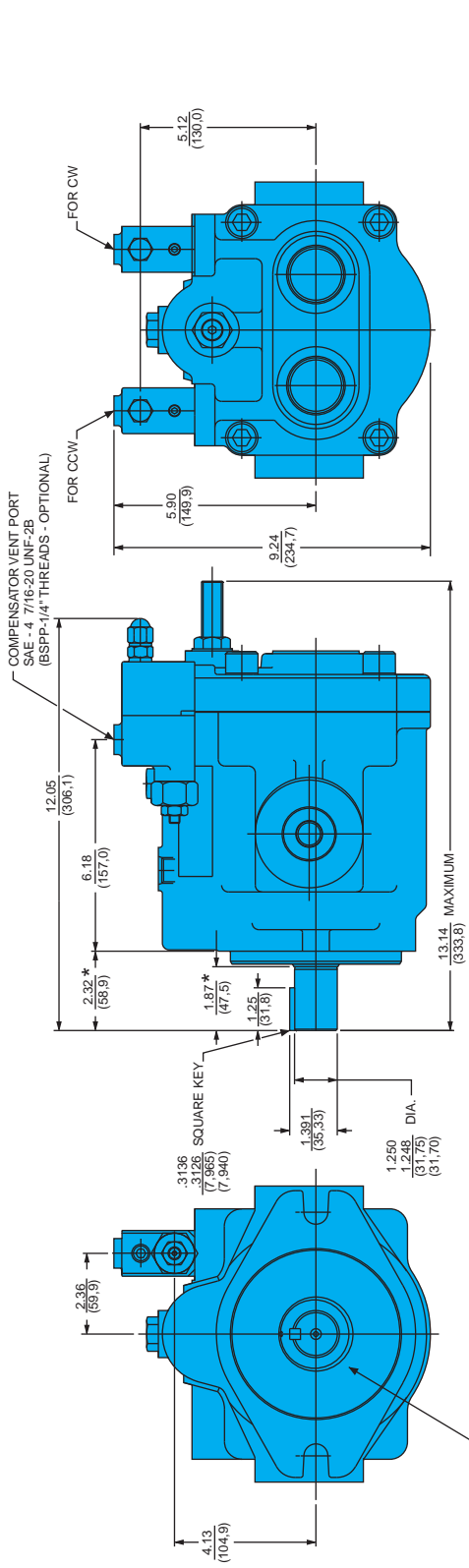

**"F" AND "L" COMPENSATOR - KEYED SHAFT**  
(SPLINED SHAFT SHOWN BELOW)

NOTE:  
TWO BOLT MOUNTING FLANGE CONFORMS TO SAE 127-2 (SAE C) SPECIFICATIONS WITH THE FOLLOWING EXCEPTIONS:  
1. THERE IS NO 2.50 (63.5) DIA. COUNTERBORE IN FACE OF MTG. FLANGE.  
2. DIMENSIONS MARKED WITH AN ASTERISK \* \*.

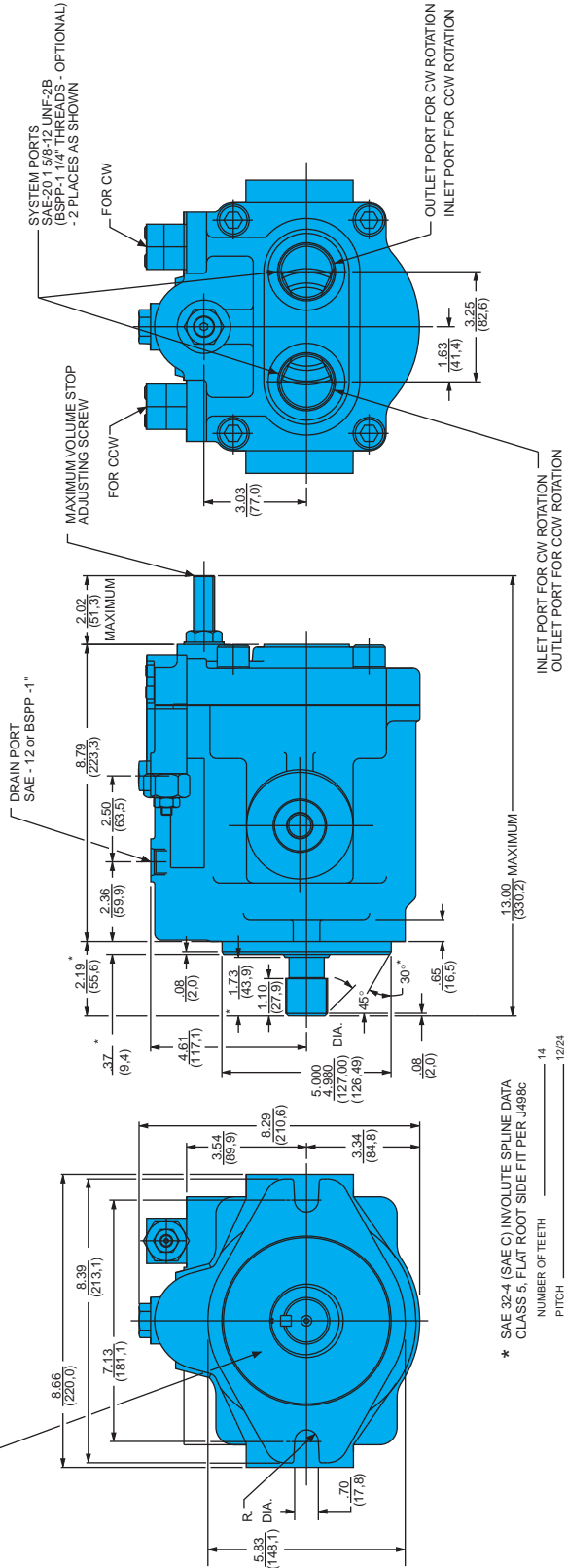

**"C" COMPENSATOR - SPLINED SHAFT**  
(KEYED SHAFT SHOWN ABOVE)  
\* Series PV29

\* SAE 32-4 (SAE C) INVOLUTE SPLINE DATA  
CLASS 5, FLAT ROOT SIDE FIT PER J498c

NUMBER OF TEETH 14

PITCH 12/24

PRESSURE ANGLE 30°

MAJOR DIA. 1.2501(224) (31.7501(09))

MINOR DIA. 1.040 (26.4)

NOTE: DIMENSIONS IN PARENTHESIS ARE METRIC (SI UNITS).



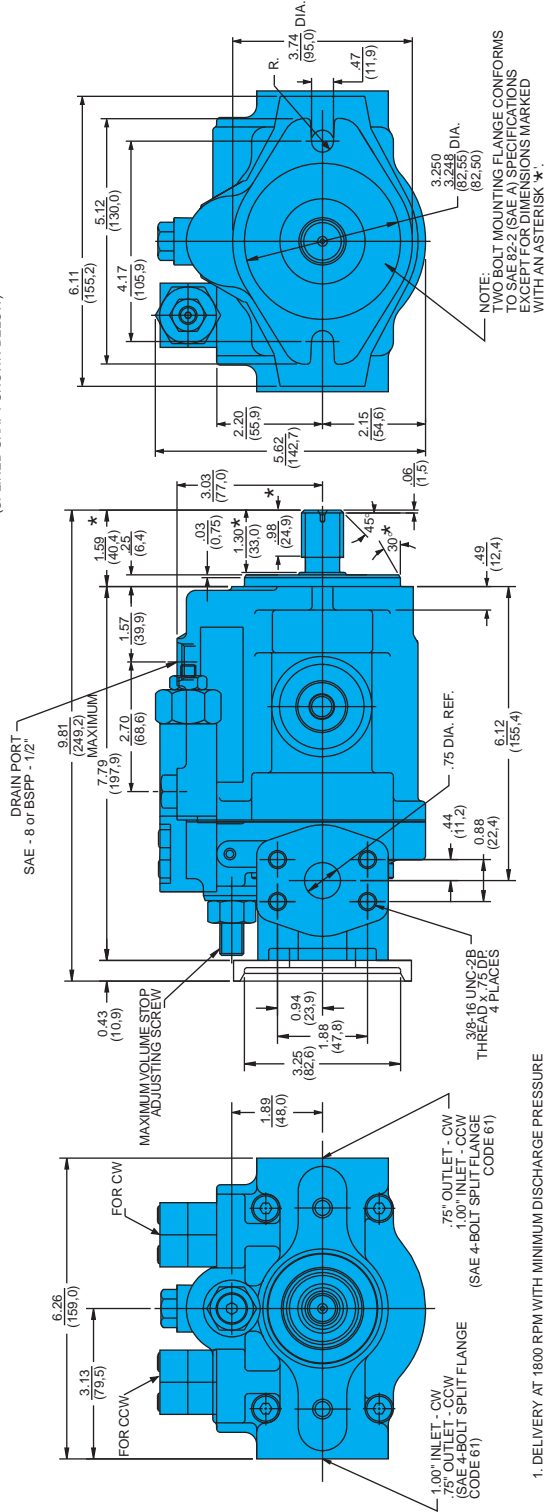
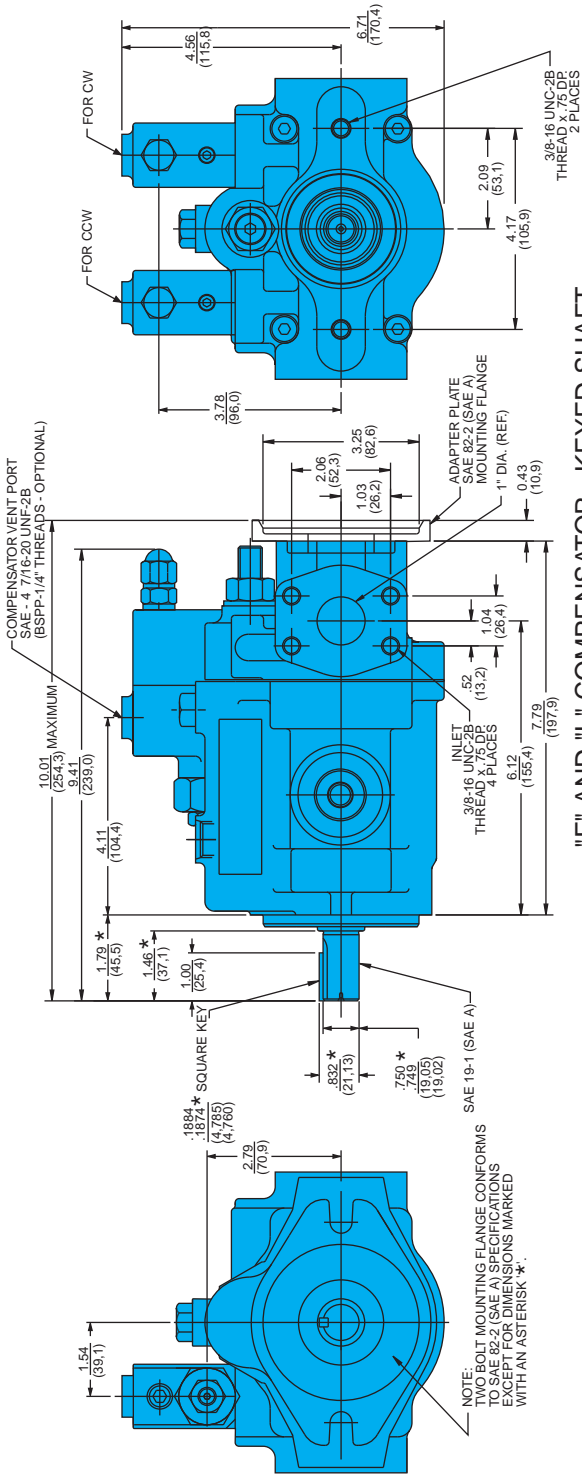

1. DELIVERY AT 1800 RPM WITH MINIMUM DISCHARGE PRESSURE

\* SAE 22-4 (SAE B) INVOLUTE SPLINE DATA CLASS 14 FULL ROOT SIDE FIT PER J4846

NUMBER OF TEETH \_\_\_\_\_ 16/32

PITCH \_\_\_\_\_ 30°

PRESSURE ANGLE \_\_\_\_\_ 87.5/85.3 (22.23/21.67)

MAJOR DIA. \_\_\_\_\_ 715 (181.6) MIN.

MINOR DIA. \_\_\_\_\_

NOTE: DIMENSIONS IN PARENTHESIS ARE METRIC (SI UNITS).

"D" SERIES PVT6

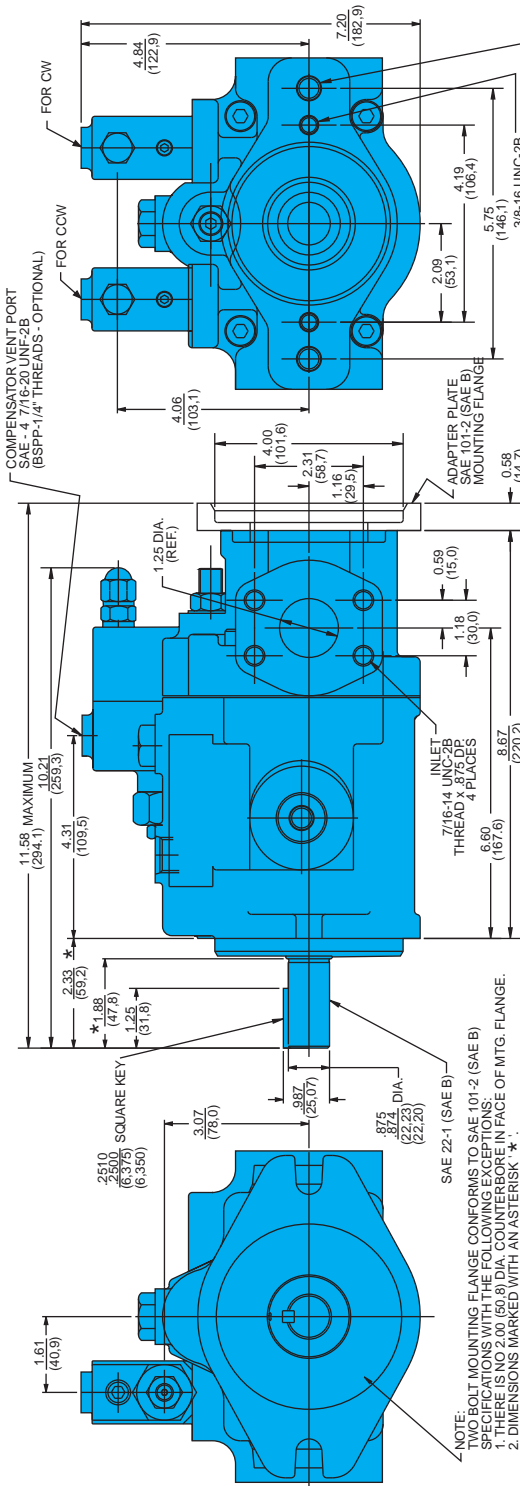

"F" AND "L" COMPENSATOR - KEYED SHAFT  
(SPLINED SHAFT SHOWN BELOW)

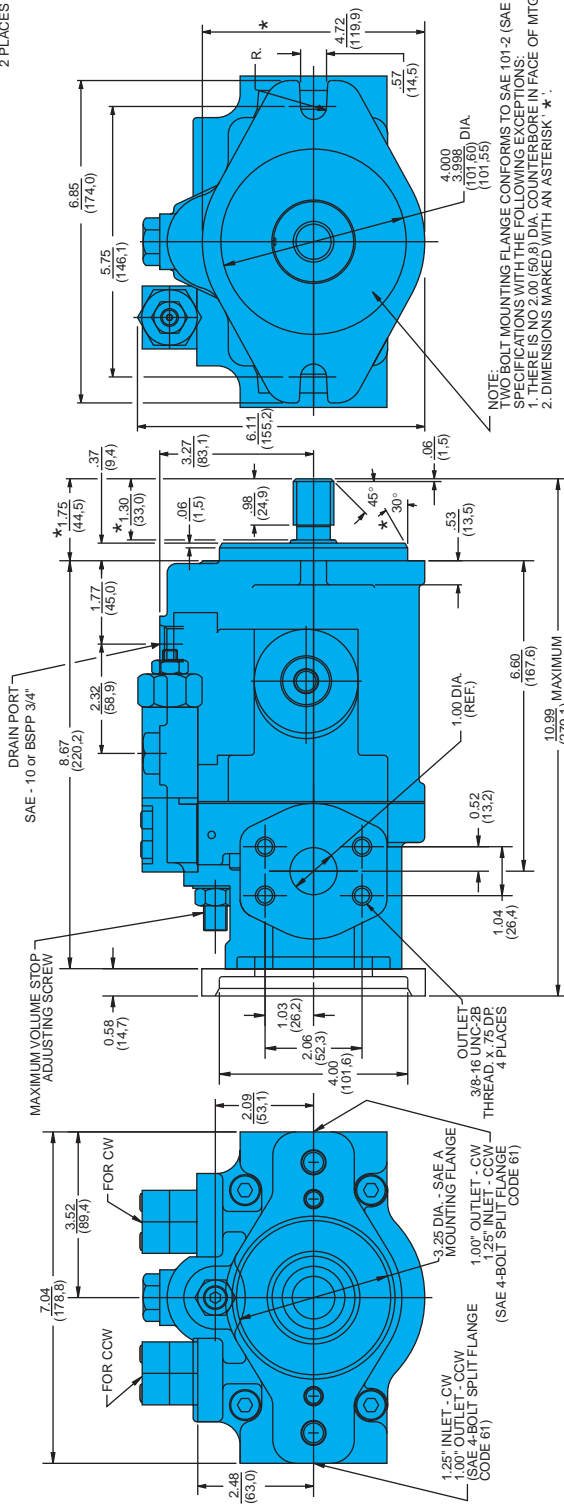

SAE 22-4 (SAE B) INVOLUTE SPLINE DATA  
CLASS 14 AT ROT SIDE FIT PER J4986

NUMBER OF TEETH	16/32
PITCH	16/32
PRESSURE ANGLE	30°
MAJOR DIA.	875/653 (22.2321.67)
MINOR DIA.	715 (18.16)

NOTE: DIMENSIONS IN PARENTHESIS ARE METRIC (SI UNITS).

"C" COMPENSATOR - SPLINED SHAFT  
(KEYED SHAFT SHOWN ABOVE)

"D" SERIES PVT10



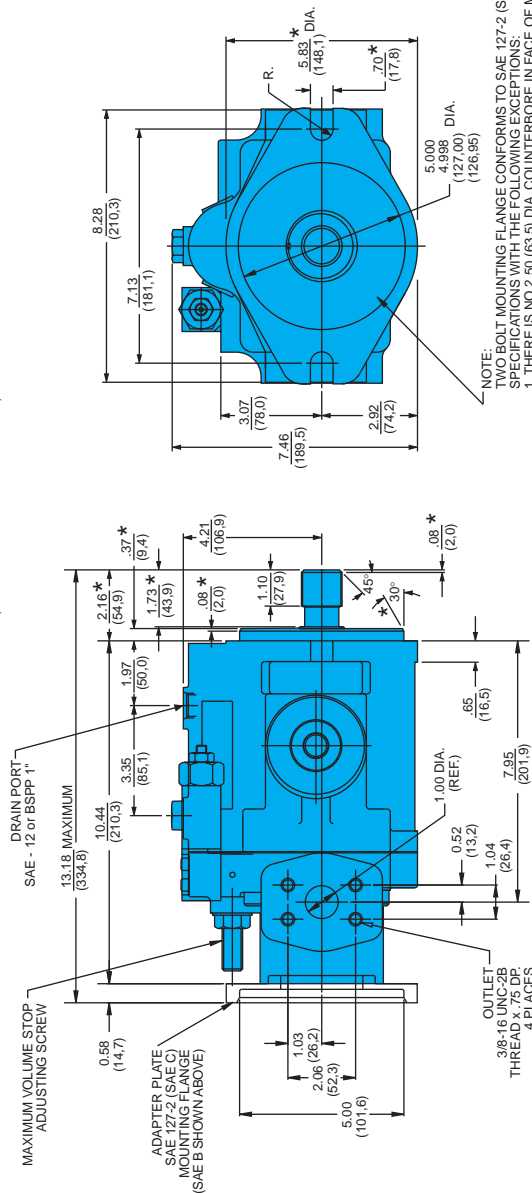
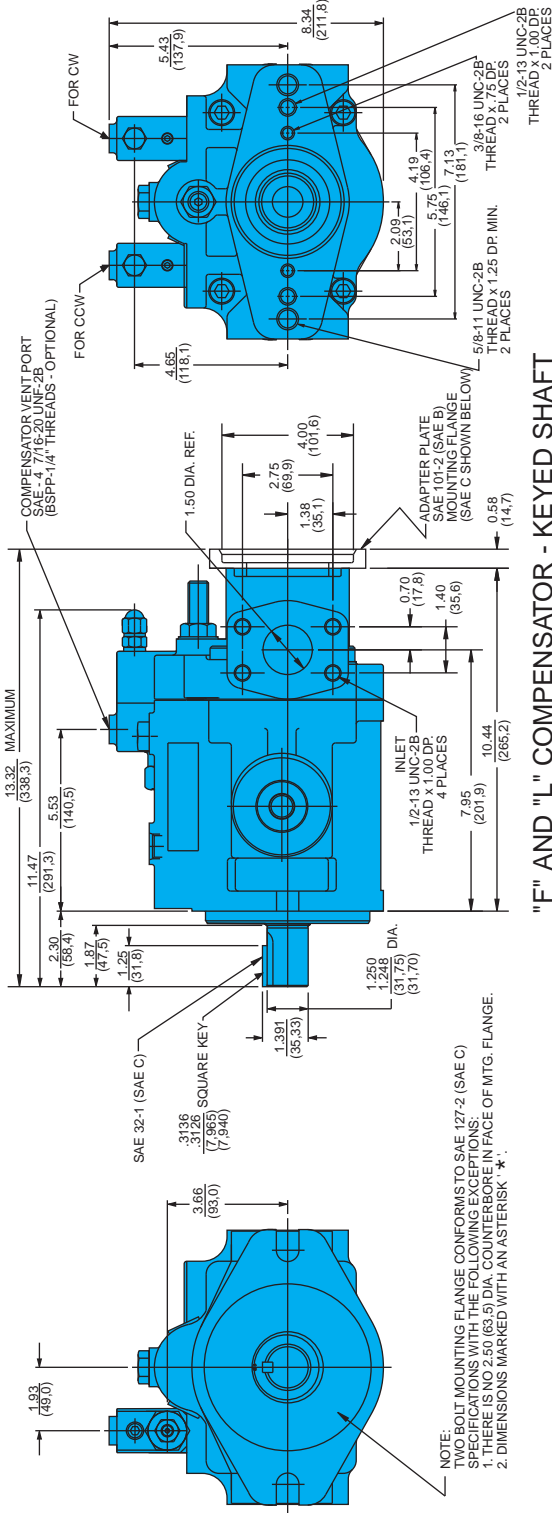

SAE 32-4 (SAE C) INVOLUTE SPLINE DATA  
CLASS 5, FLAT ROOT SIDE FIT PER J498c

NUMBER OF TEETH	14
PITCH	12/24
PRESSURE ANGLE	30°
MAJOR DIA.	1.250/1.224 (31.75/31.09)
MINOR DIA.	1.040 (26.4)

NOTE: DIMENSIONS IN PARENTHESIS ARE METRIC (SI UNITS).

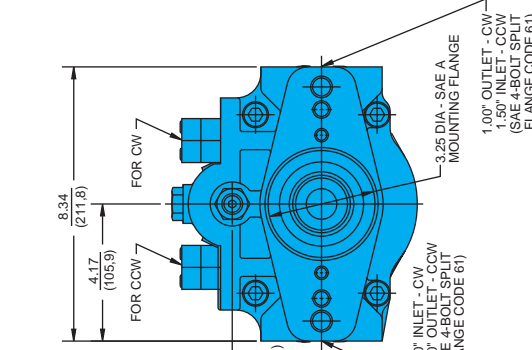
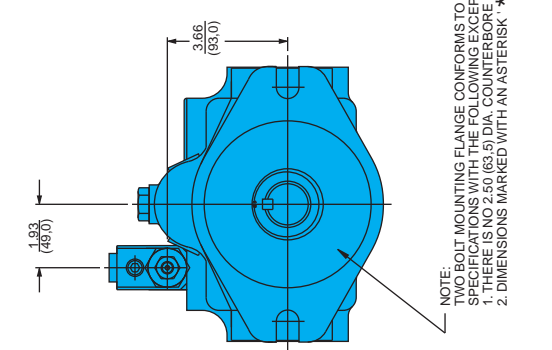

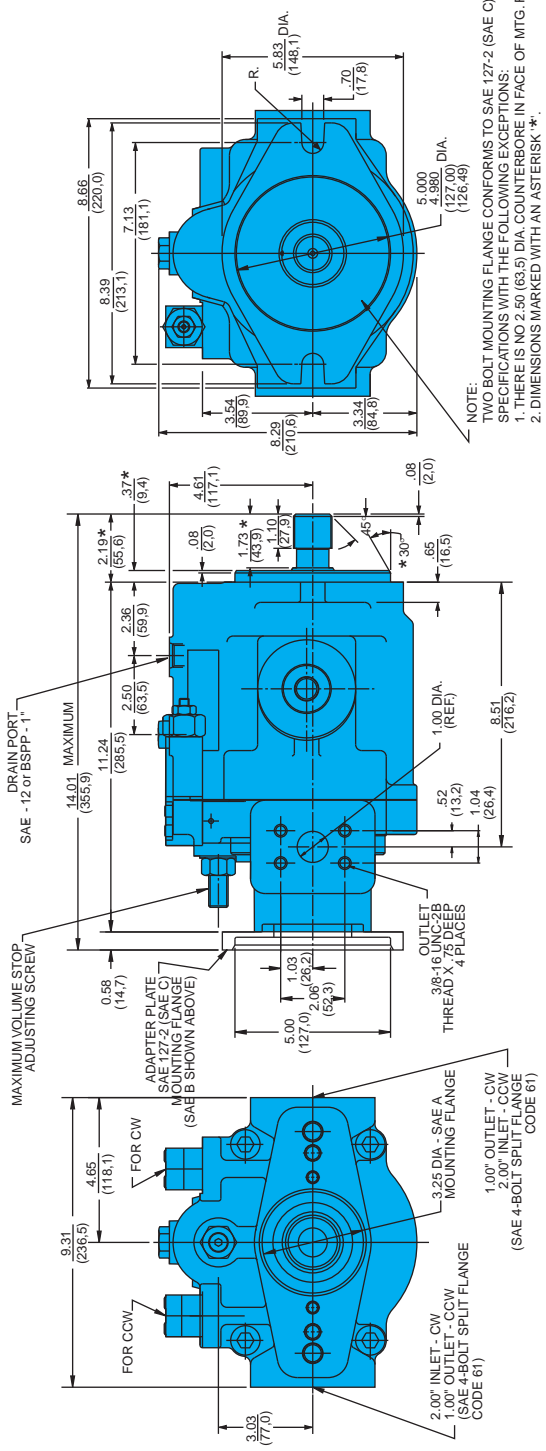
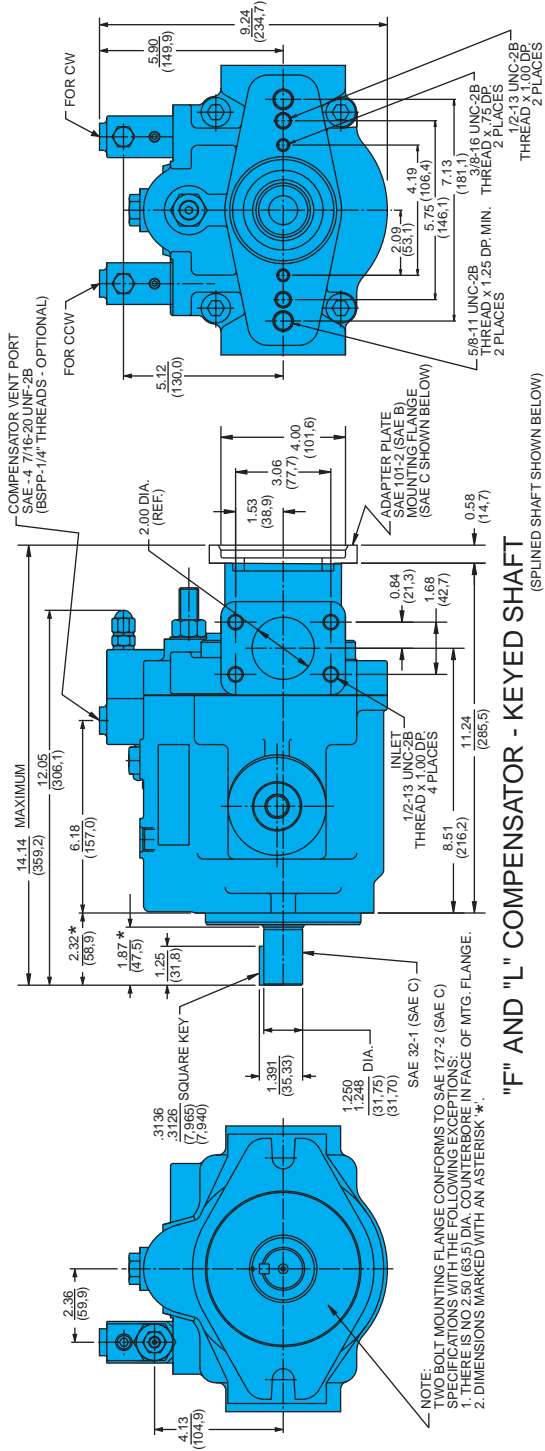

NOTE:  
TWO BOLT MOUNTING FLANGE CONFORMS TO SAE 127-2 (SAE C)  
SPECIFICATIONS WITH THE FOLLOWING EXCEPTIONS:  
1. THERE IS NO 2.50 (63.5) DIA. COUNTERBORE IN FACE OF MTG. FLANGE.  
2. DIMENSIONS MARKED WITH AN ASTERISK "\*".

MAXIMUM VOLUME STOP  
ADJUSTING SCREW  
SAE -12 or BSPP-1"

14.01 MAXIMUM (355.9)

11.24 (285.5)

2.19\* (55.6)

.37\* (9.4)

2.36 (59.9)

2.50 (63.5)

0.58 (14.7)

0.58 (14.7)

1.03 (26.2)

5.00 (127.0)

1.03 (26.2)

1.73\* (43.9)

1.10 (27.9)

4.61 (117.1)

.08 (2.0)

.65 (16.5)

.30

1.00 DIA. (REF.)

.52 (13.2)

1.04 (26.4)

8.51 (216.2)

OUTLET  
3/8-16 UNC-2B  
THREAD X .75 DEEP  
4 PLACES

2.00" INLET - CW  
1.00" OUTLET - CCW  
(SAE 4-BOLT SPLIT FLANGE  
CODE 61)

1.00" OUTLET - CW  
2.00" OUTLET - CCW  
(SAE 4-BOLT SPLIT FLANGE  
CODE 61)

SAE 32-4 (SAE C) INVOLUTE SPLINE DATA  
CLASS 5, FLAT ROOT SIDE FIT PER J498C  
NUMBER OF TEETH 14  
PITCH 12/24  
PRESSURE ANGLE 30°  
MAJOR DIA. 1.250/1.224 (31.75/31.09)  
MINOR DIA. 1.040 (26.4)  
NOTE: DIMENSIONS IN PARENTHESIS ARE METRIC (SI UNITS).











## Torque Limiter

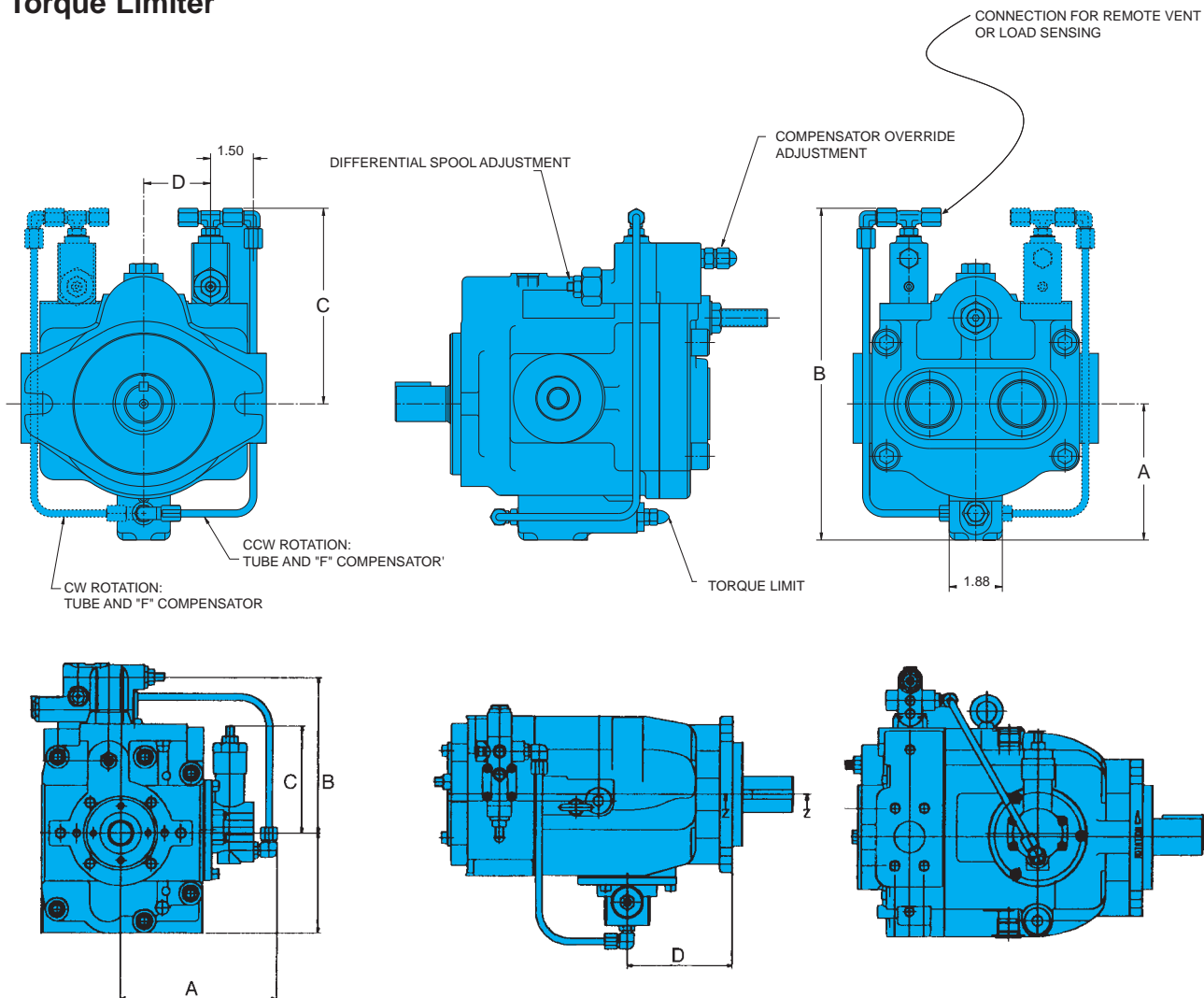

## Torque Values

	Max. Pressure psi	Max. Pressure bar	Max. Torque in-lb	Max. Torque Nm	J* torque range in-lb min	K* torque range in-lb min.	J* torque range Nm min.	K* torque range Nm min.
PV6/PVT6	4500	310	685	77	88	274	10	31
PV10/PVT10	4500	310	981	111	257	407	29	46
PV15/PVT15	4500	310	1627	184	407	619	46	70
PV20/PVT20	4500	310	2040	231	531	725	60	82
PV29/PVT29	4000	275	2616	296	681	1044	77	118
PVT38	4350	300	3672	415	946	1318	107	149
PVT47	4350	300	4590	519	1185	1645	134	186
PVT64	4350	300	5968	675	1512	2087	171	236

\* Use J limiter from listed minimum to K value

\* Use K limiter from listed minimum to Maximum Torque value value

PV PVT	A	B	C	D
6	3.50 (88.9)	9.06 (230.1)	5.56 (141.2)	1.54 (39.1)
10	4.00 (101.6)	9.84 (249.9)	5.84 (148.3)	1.61 (40.9)
15	4.38 (111.3)	10.61 (269.5)	6.23 (158.2)	1.89 (48.0)
20	4.63 (117.6)	11.06 (280.9)	6.43 (163.3)	1.93 (49.0)
29	5.00 (127.0)	11.90 (302.3)	6.90 (175.3)	2.36 (59.9)
38	7.10 (180.3)	7.02 (178.3)	5.12 (131.0)	4.57 (116.0)
47	7.46 (189.6)	7.53 (191.3)	5.20 (132.0)	5.08 (129.0)
64	8.02 (203.8)	7.85 (199.3)	4.92 (125.0)	5.98 (152.0)

## F and L Compensators

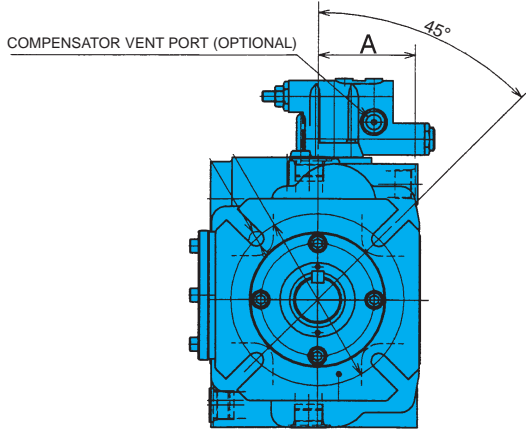

	PVT 38	PVT47	PVT64
A	2.78 (70.6)	3.59 (91.1)	4.16 (105.6)
B	12.97 (329.5)	14.46 (367.2)	16.26 (413.0)
C	10.02 (254.5)	11.32 (287.5)	12.24 (311.0)
D	11.20 (284.5)	12.50 (317.5)	13.43 (341.0)
E	8.84 (224.5)	10.14 (257.5)	11.06 (281.0)
F	4.76 (121.0)	5.28 (134.0)	5.59 (142.0)
G	7.02 (178.3)	7.53 (191.3)	7.85 (199.3)
H	7.69 (195.3)	8.20 (208.3)	8.52 (216.3)
I	6.07 (154.3)	6.59 (167.3)	6.90 (175.3)
J	5.44 (138.3)	5.96 (151.3)	6.27 (159.3)

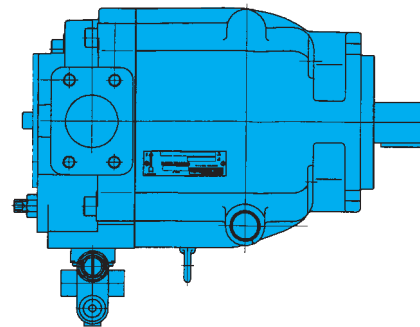
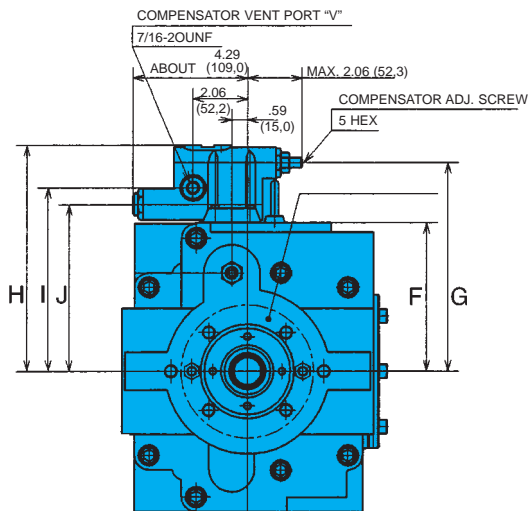
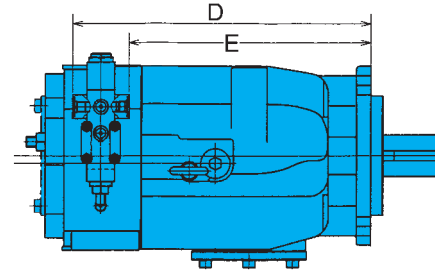
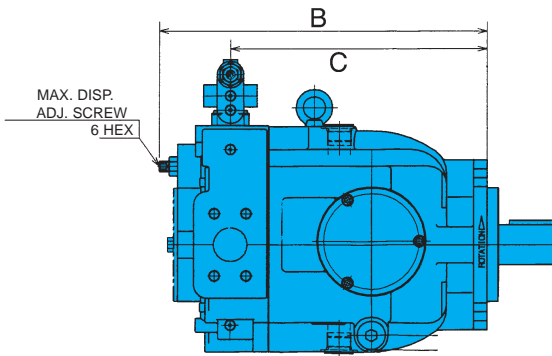

SAE - A REAR DRIVE

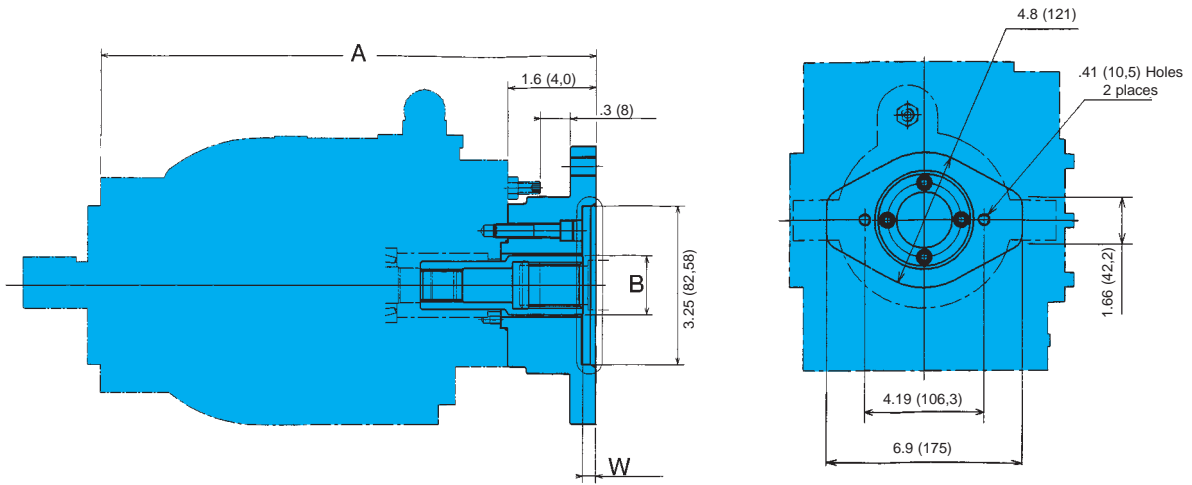

	A	B	W
PVT38	13.68 (347,5)	1.5 (38)	.492 (12,50)
PVT47	15.21 (386,4)	1.7 (44)	.531 (13,51)
PVT64	16.97 (431,0)	1.7 (44)	.496 (12,60)

SAE - B REAR DRIVE

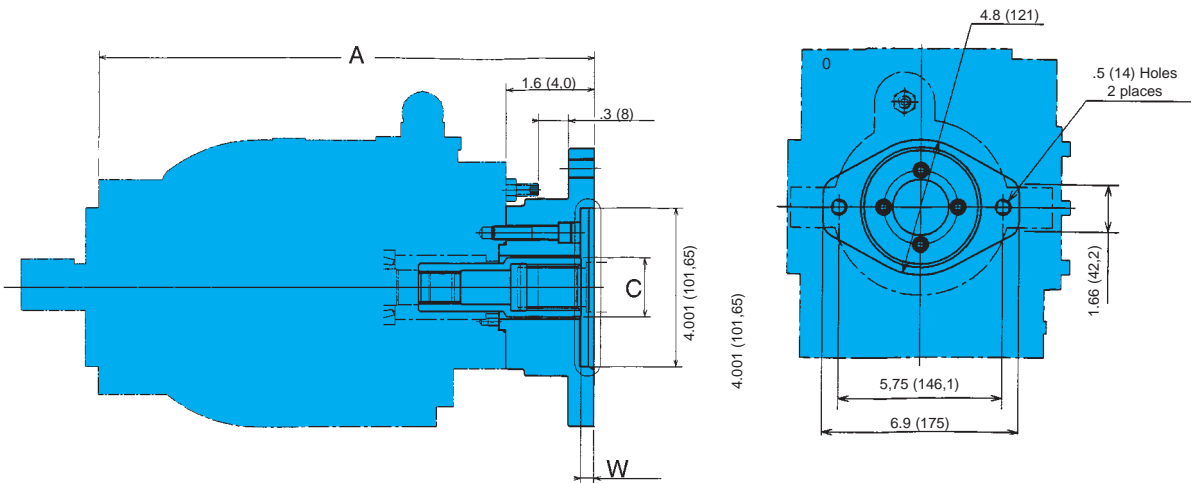

	A	C	W
PVT38	13.68 (347,5)	1.5 (38)	.492 (12,50)
PVT47	15.21 (386,4)	1.7 (44)	.531 (13,51)
PVT64	16.97 (431,0)	1.7 (44)	.496 (12,60)

SAE - BB REAR DRIVE

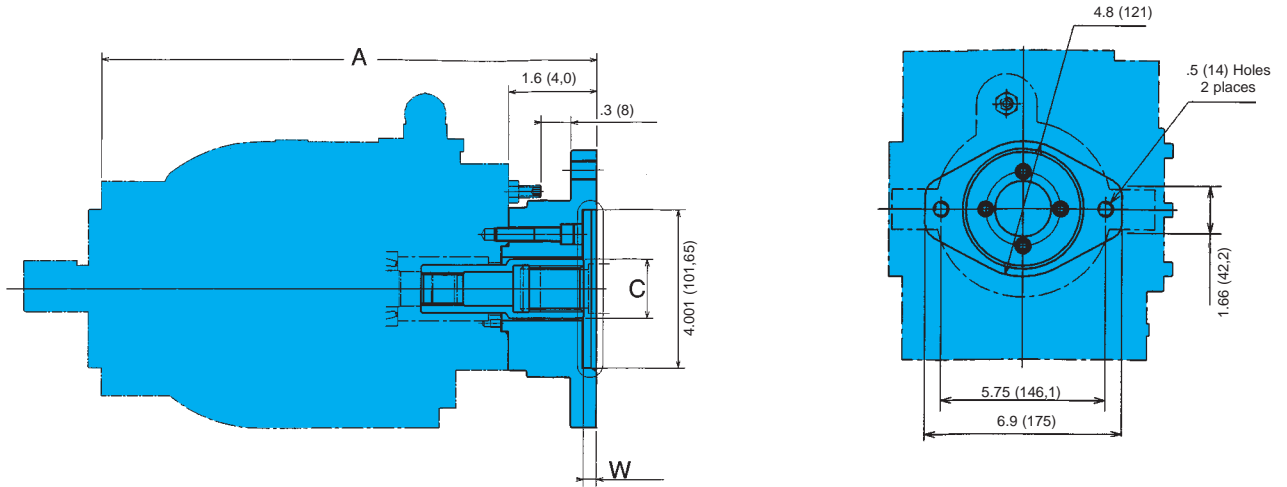

	A	C	W
PVT38	13.68 (347,5)	1.5 (38)	.492 (12,50)
PVT47	15.21 (386,4)	1.7 (44)	.531 (13,51)
PVT64	16.97 (431,0)	1.7 (44)	.496 (12,60)

SAE - C REAR DRIVE

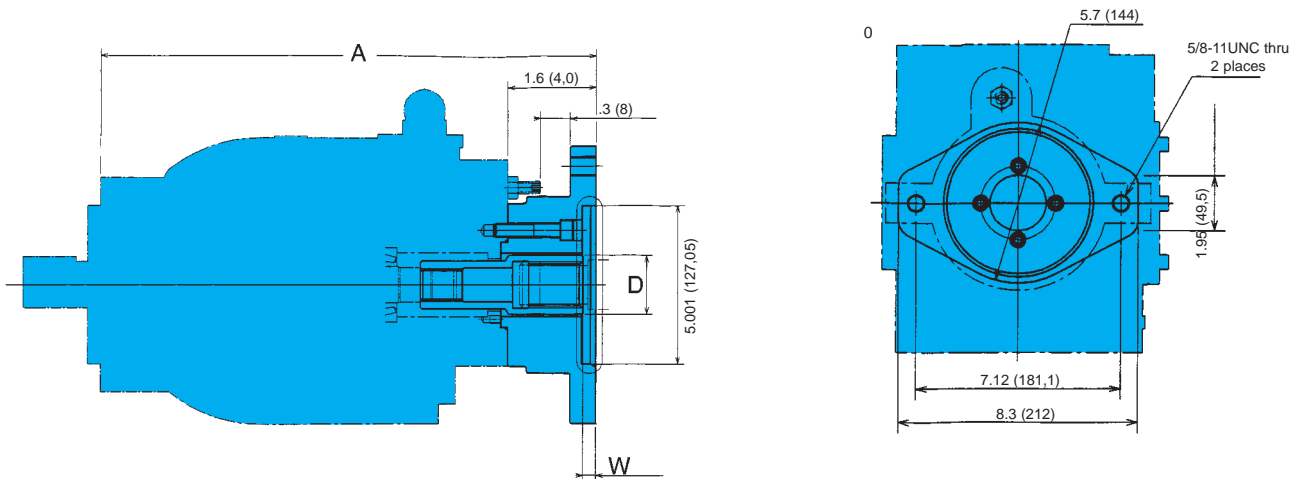

	A	D	W
PVT38	13.68 (347,5)	1.7 (44)	.492 (12,50)
PVT47	15.21 (386,4)	1.7 (44)	.531 (13,51)
PVT64	16.97 (431,0)	1.7 (44)	.496 (12,60)

SAE - CC REAR DRIVE

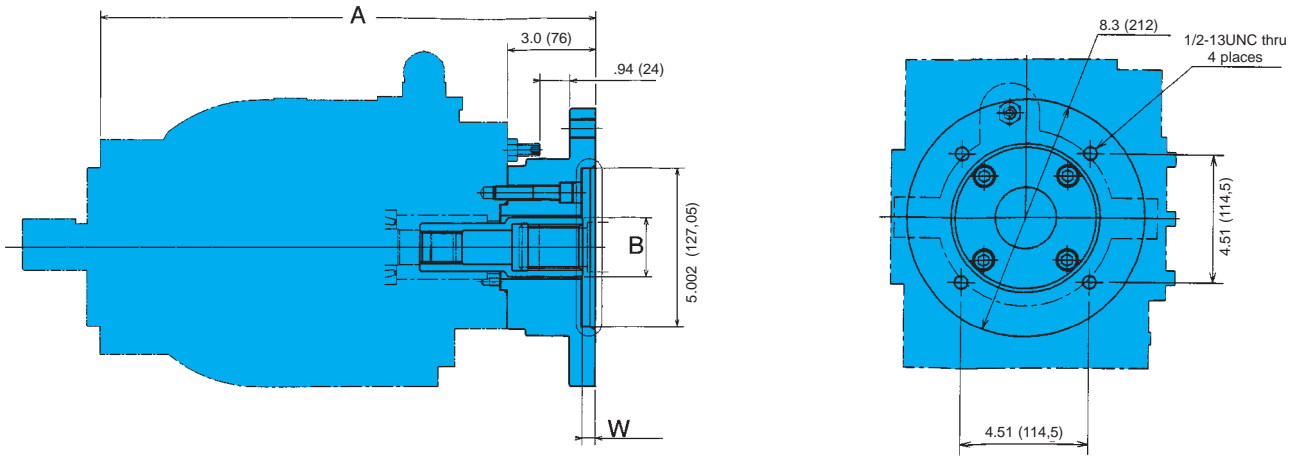

	A	B	W
PVT38	15.10 (383,5)	2.0 (51)	.492 (12,50)
PVT47	16.62 (422,4)	2.0 (51)	.531 (13,51)
PVT64	18.39 (467,0)	2.0 (51)	.496 (12,60)

SAE - D REAR DRIVE

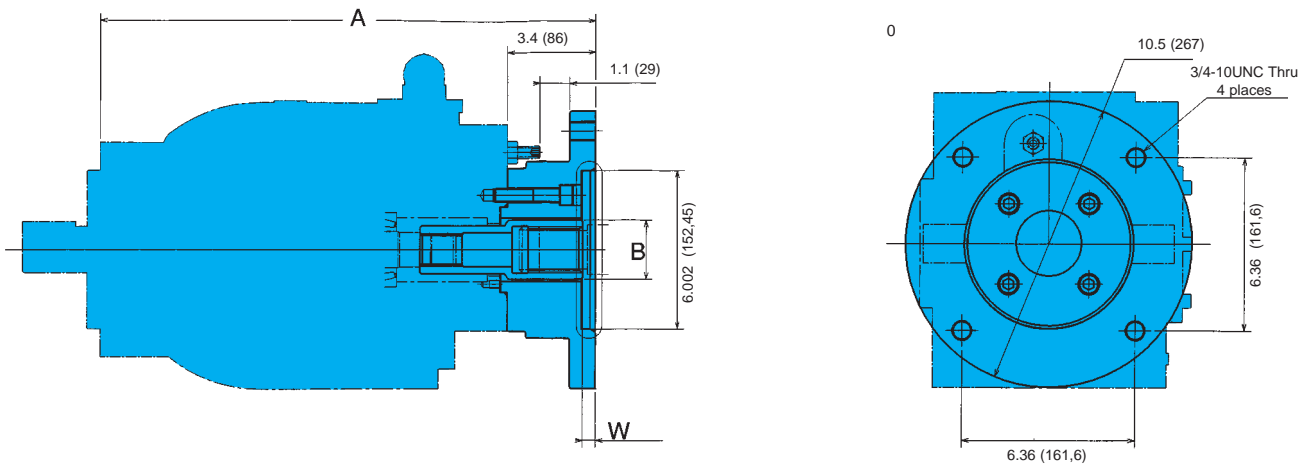

	A	B	W
PVT64	18.8 (477)	2.2 (57)	.496 (12,60)

@ 1800 RPM

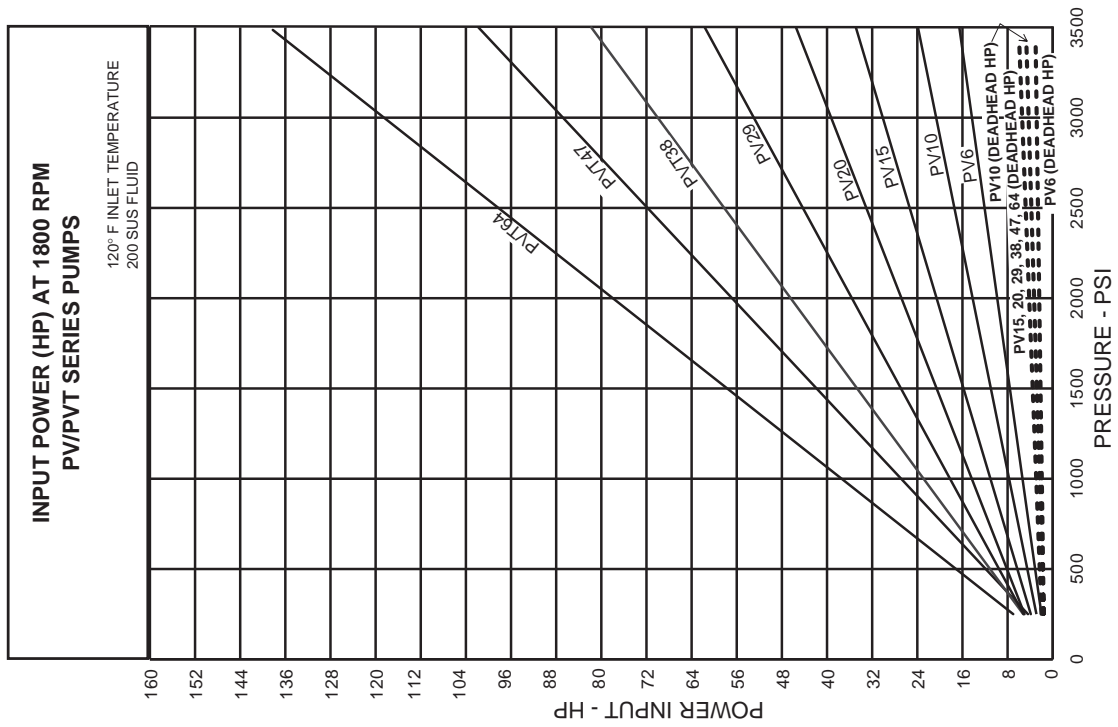
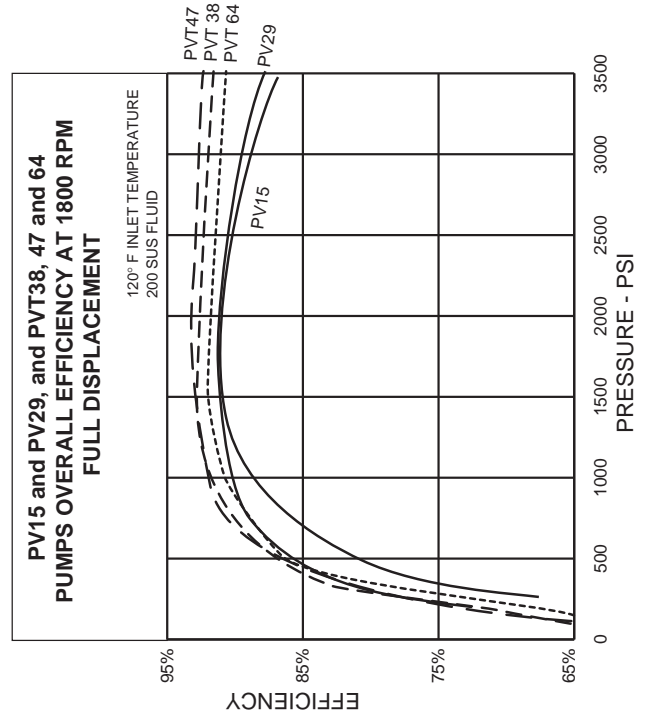
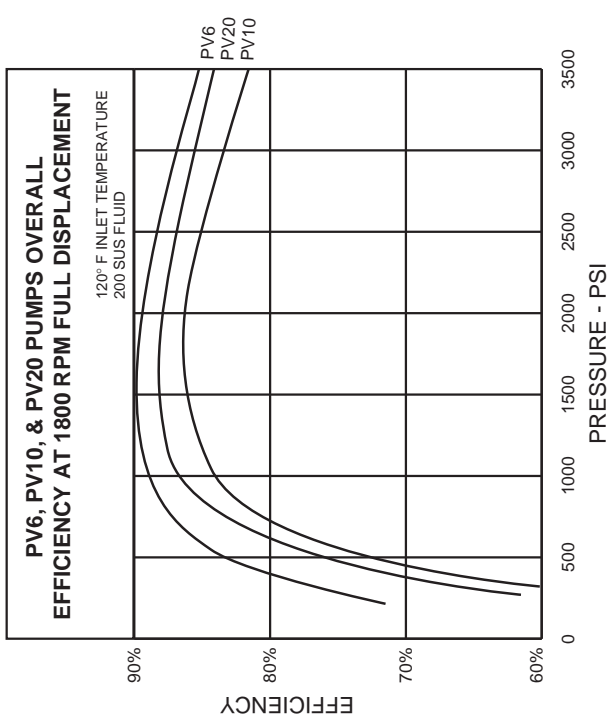



@ 1800 RPM

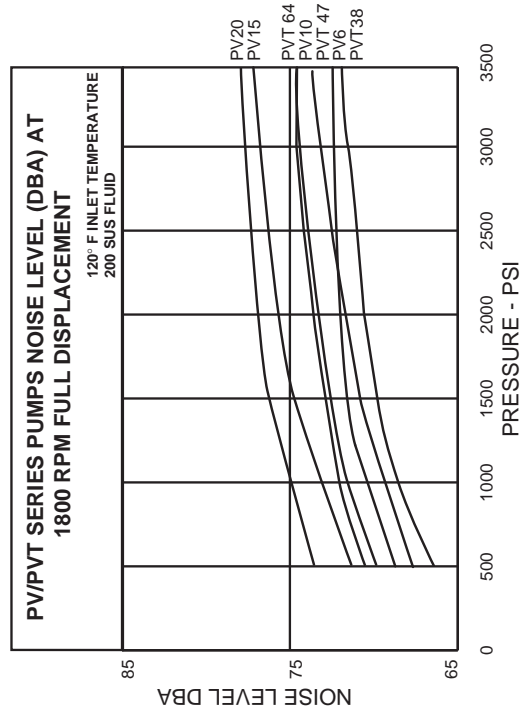
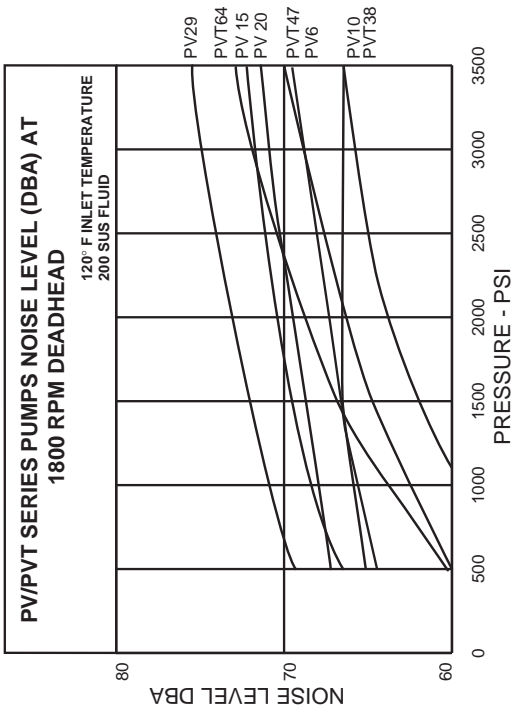
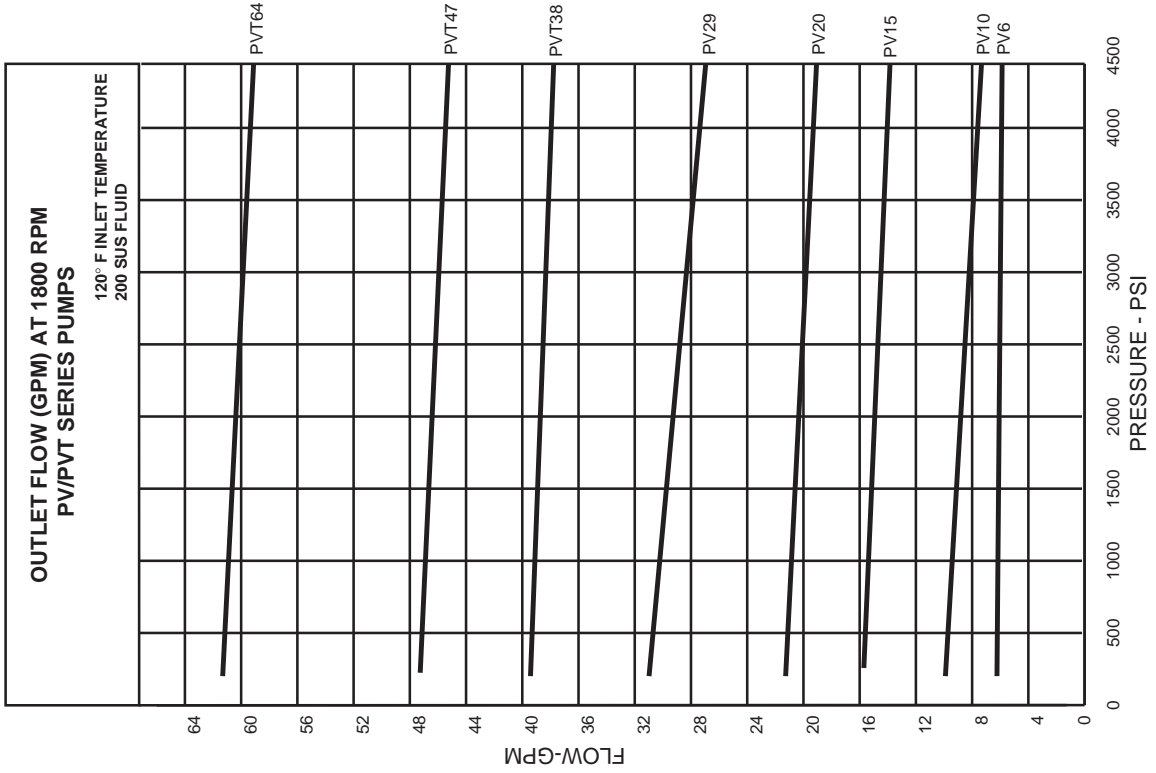

@ 1500 RPM

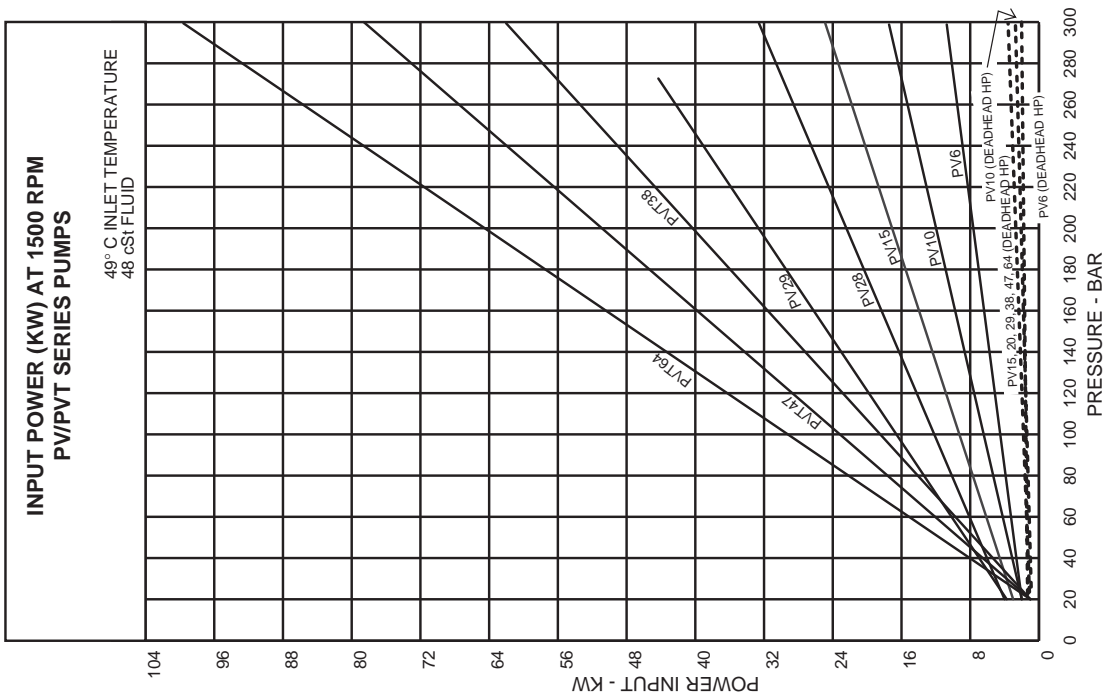
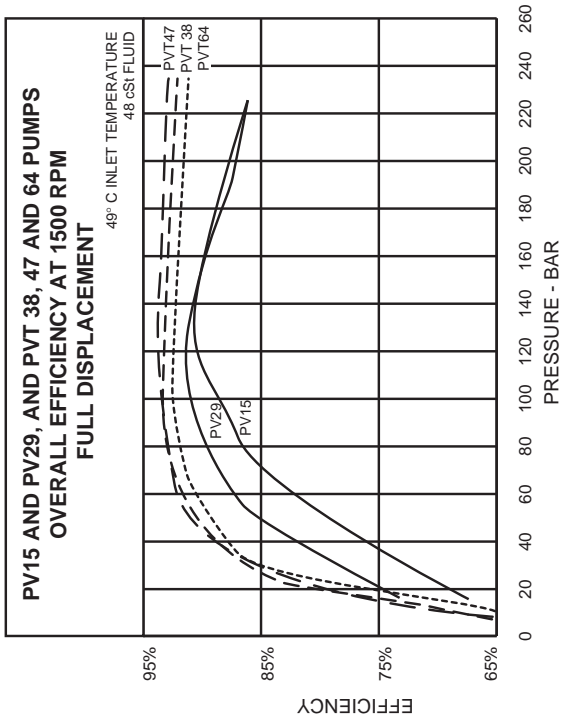
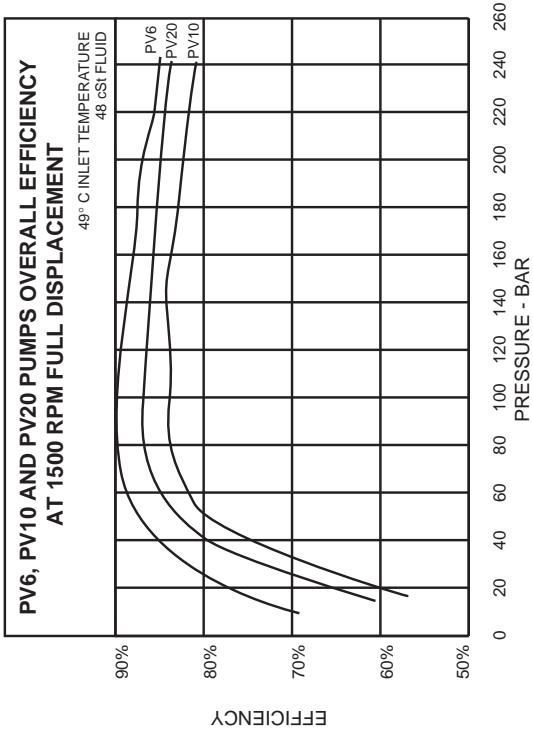

@ 1500 RPM

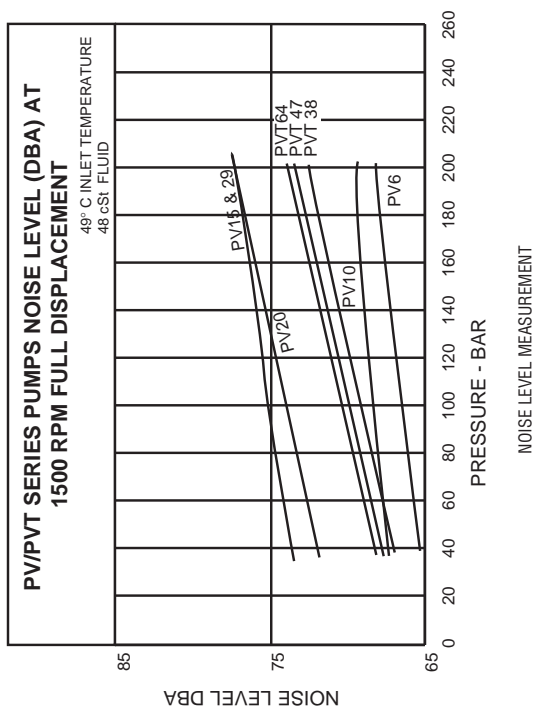
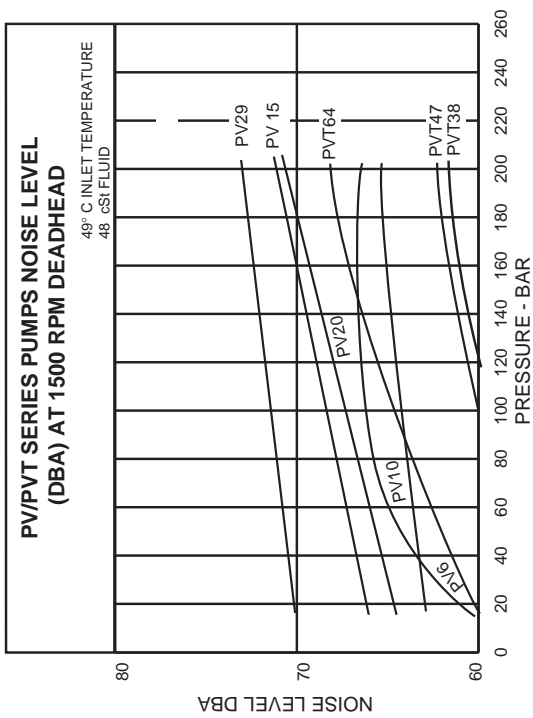
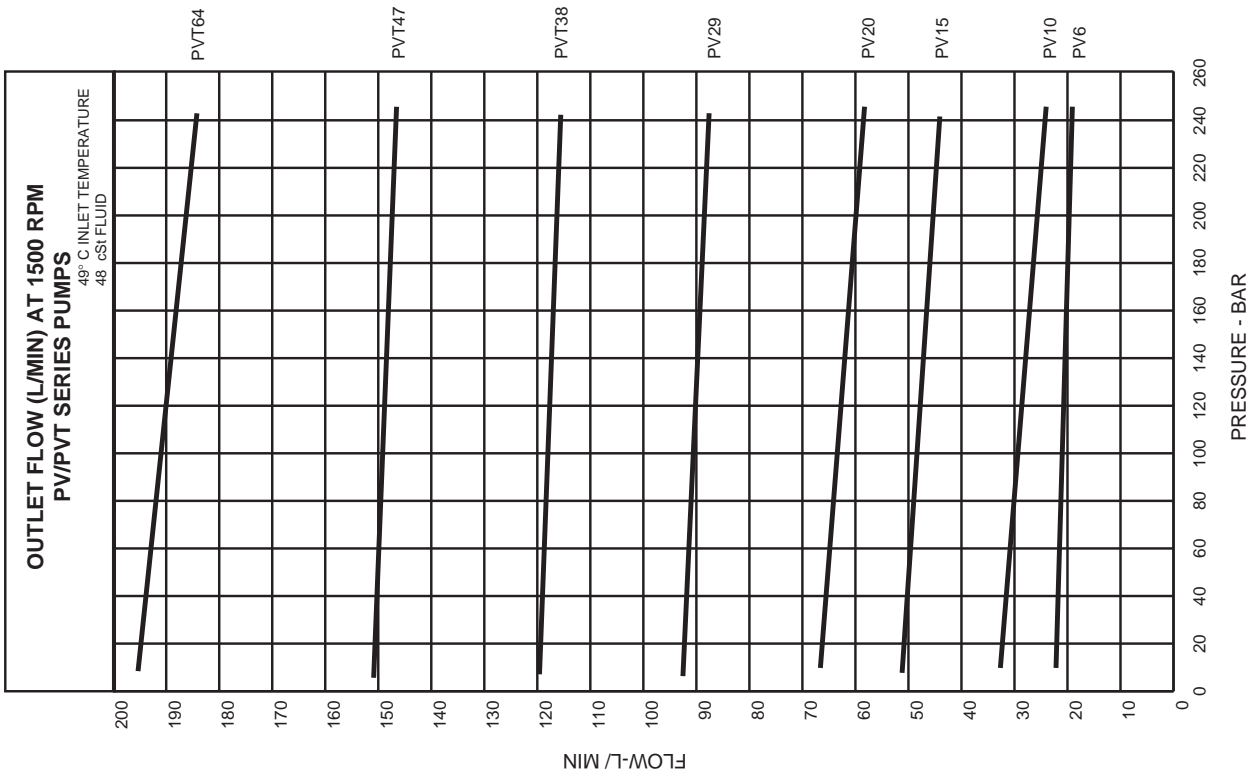

MEASUREMENTS OF PUMP ACOUSTICAL DATA WERE MADE IN ACCORDANCE WITH ANSI B93.71M-1986, HYDRAULIC FLUID POWER-PUMPS-TEST CODE FOR THE DETERMINATION OF AIRBORNE NOISE LEVELS. (TECHNICALLY SIMILAR TO ISO 4412-1)

THE MEASUREMENTS WERE MADE IN A SPECIAL REVERBERANT TEST ROOM IN THE DENISON HYDRAULICS MARYSVILLE FACILITY WHICH WAS QUALIFIED TO ANSI S12.23-1990, (REVISION OF ANSI S1.33-1982). ENGINEERING METHODS FOR THE DETERMINATION OF SOUND POWER LEVELS OF NOISE SOURCES IN A SPECIAL REVERBERATION TEST ROOM.

PV 6 -2 R 1 C -C 0 0 -A A 0

**Pump series**

- PV -variable volume pump - no rear drive
- PVT -variable volume pump - side ported or rear drive
- PVM -mobile version, rear port, PV20 only
- PVR -mobile version, side port, PV20 only

**Flow at 1800 rpm**

- 6 -6.8 gpm, 25,7 Lpm
- 10 -10.0 gpm, 37,9 Lpm
- 15 -16.3 gpm, 61,7 Lpm
- 20 -20.4 gpm, 77,2 Lpm
- 29 -29.5 gpm, 111,7 Lpm
- 38 -38.0 gpm, 144,0 Lpm
- 47 -47.6 gpm, 180,0 Lpm
- 64 -61.8 gpm, 234,0 Lpm

**Shaft**

- 1 -splined
- 2 -keyed
- 4 -splined- SAE 25-4 (SAE B-B) (for PVT15 only)
- 5 -keyed- SAE 25-1 (SAE B-B) (for PVT15 only)

**Rotation**

- R -CW
- L -CCW

**Seals**

- 1 -Buna compound
- 5 -Viton compound

**Design**

- C -assigned by manufacturer

**Control**

- C -compensator
- F -ventable compensator
- L -load sense compensator
- J -low torque limiter (max. pressure below 3000 PSI, 207 BAR)
- K -high torque limiter (max. pressure above 3000 PSI, 207 BAR)

**Control accessories**

- 0 -maximum volume adjustment screw

**Fluid connections**

- 0 -SAE straight thread sizes 6-29 only
- 2 -BSPP thread sizes 6-29 only
- 3 -SAE, with 4 bolt flange system ports sizes 6-64 only
- 4 -BSP, with SAE-4 bolt flange system ports sizes 6-29 only

**Rear drive**

- 0 -none-rear ported sizes 6-29 only
- S -none-side ported sizes 6-64 only
- A -SAE-82 (SAE A) sizes 6-64 only
- B -SAE-101 (SAE B) sizes 10-64 only
- C -SAE-127 (SAE C) sizes 15-64 only
- D -SAE-152 (SAE D) size 64 only

**Couplings**

- 0 -none sizes 6-64 only
- A -SAE-16-4 (SAE A) sizes 6-64 only
- B -SAE-22-4 (SAE B) sizes 10-64 only
- Q -SAE-25-4 (SAE B-B) sizes 38-64 only
- C -SAE-32-4 (SAE C) sizes 15-64 only
- R -SAE-38-4 (SAE-CC) sizes 38-64 only
- D -SAE-44-4 (SAE-D) size 64 only

**Rear mounted pump**

- 0 -none
- 1 -mounted

**Shaft sizes**

	SAE-	spline	key
PV6, PVT6	SAE-	22-4 (B)	19-1 (A)
PV10, PVT10	SAE-	22-4 (B)	22-1 (B)
PV15, PVT15	SAE-	22-4 (B)	22-1 (B)
PVT15 (use 4, 5)	SAE-	25-4 (B-B)	25-1 (B-B)
PV20, PVT20	SAE-	32-4 (C)	32-1 (C)
PVM20/PVR20	SAE-	32-4 (C)	32-1 (C)
PV29, PVT29	SAE-	32-4 (C)	32-1 (C)
PVT38	SAE-	38-4 (CC)	38-1 (CC)
PVT47	SAE-	38-4 (CC)	44-1 (D)
PVT64	SAE-	44-4 (D)	44-1 (D)

**Allowable controls:** C00, C02, C03, C04, F00, F02, F03, F04, J00, J02, J03, J04, K00, K02, K03, K04, L00, L02, L03, L04

## CONVERSIONS & FORMULAS

### DEFINITION & UNIT

<i>displacement</i>	$\text{in}^3/\text{rev} \times 16.387 = \text{cm}^3/\text{rev}$	$\text{cm}^3/\text{rev} \times 0.06102 = \text{in}^3/\text{rev}$
<i>flow</i>	$\text{gpm} \times 3.78 = \text{L}/\text{min}$	$\text{L}/\text{min} \times 0.2642 = \text{gpm}$
<i>power</i>	$\text{hp} \times 0.7457 = \text{kW}$	$\text{kW} \times 1.341 = \text{hp}$
<i>torque</i>	$\text{lb-ft} \times 1.3567 = \text{Nm}$	$\text{Nm} \times 0.7376 = \text{lb-ft}$
<i>pressure</i>	$\text{lbs}/\text{in}^2 \text{ (psi)} \times 0.06895 = \text{bar}$ $\text{lbs}/\text{in}^2 \text{ (psi)} \times 6.895 = \text{kPa}$	$\text{bar} \times 14.50 = \text{lbs}/\text{in}^2 \text{ (psi)}$ $\text{kPa} \times 0.1450 = \text{lbs}/\text{in}^2 \text{ (psi)}$
<i>weight</i>	$\text{lb} \times 0.4536 = \text{kg}$	$\text{kg} \times 2.205 = \text{lbs}$
<i>force</i>	$\text{lb} \times 4.448 = \text{N}$	$\text{N} \times 0.2248 = \text{lbs}$
<i>volume</i>	$\text{in}^3 \times 16.387 = \text{cm}^3$	$\text{cm}^3 \times 0.06102 = \text{in}^3$
<i>area</i>	$\text{in}^2 \times 6.452 = \text{cm}^2$	$\text{cm}^2 \times 0.1550 = \text{in}^2$
<i>length</i>	$\text{in} \times 25.4 = \text{mm}$	$\text{mm} \times 0.03937 = \text{in}$
<i>temperature</i>	$\text{degree F} - 32 = \text{ }^\circ\text{C}$ 1.8	$1.8 \times \text{ }^\circ\text{C} + 32 = \text{ }^\circ\text{F}$
<i>viscosity</i>	$\text{cSt} \times 1.0 = \text{mm}^2/\text{sec}$	$\text{mm}^2/\text{sec} \times 1.0 = \text{cSt}$

### FLUID POWER FORMULAS

<i>Pump input torque</i>	<i>lbs. in.</i>	$\frac{\text{pressure}(\text{psi}) \times \text{displacement} (\text{in}^3/\text{rev})}{2\pi \times \text{mech. eff.}}$
<i>Pump input power</i>	<i>hp</i>	$\frac{\text{rpm} \times (\text{in}^3/\text{rev}) \times (\text{psi})}{395934 \times \text{overall eff.}}$
<i>Pump output flow</i>	<i>U.S. gpm</i>	$\frac{\text{rpm} \times (\text{in}^3/\text{rev}) \times \text{volumetric eff.}}{231}$
<i>Fluid motor speed</i>	<i>rpm</i>	$\frac{231 \times \text{flow rate}(\text{U.S. gpm}) \times \text{volumetric eff.}}{\text{displacement} (\text{in}^3/\text{rev})}$
<i>Fluid motor torque</i>	<i>lbs. in.</i>	$\frac{\text{pressure}(\text{psi}) \times \text{displacement} (\text{in}^3/\text{rev}) \times \text{mech. eff.}}{2\pi}$
<i>Fluid motor power</i>	<i>hp</i>	$\frac{\text{rpm} \times (\text{in}^3/\text{rev}) \times (\text{psi}) \times \text{overall eff.}}{395934}$
<b>(metric)</b>		
<i>Pump input torque</i>	<i>Nm</i>	$\frac{\text{pressure}(\text{bar}) \times \text{displacement} (\text{cm}^3/\text{rev})}{20\pi \times \text{mech. eff.}}$
<i>Pump input power</i>	<i>kW</i>	$\frac{\text{rpm} \times (\text{cm}^3/\text{rev}) \times (\text{bar})}{600000 \times \text{overall eff.}}$
<i>Pump output flow</i>	<i>Lpm</i>	$\frac{\text{rpm} \times (\text{cm}^3/\text{rev}) \times \text{volumetric eff.}}{1000}$
<i>Fluid motor speed</i>	<i>rpm(min<sup>-1</sup>) (tr/mn)</i>	$\frac{1000 \times \text{flow rate} (\text{Lpm}) \times \text{volumetric eff.}}{\text{displacement} (\text{cm}^3/\text{rev})}$
<i>Fluid motor torque</i>	<i>Nm</i>	$\frac{\text{pressure}(\text{bar}) \times \text{displacement} (\text{cm}^3/\text{rev}) \times \text{mech. eff.}}{20\pi}$
<i>Fluid motor power</i>	<i>kW</i>	$\frac{\text{rpm} \times (\text{cm}^3/\text{rev}) \times (\text{bar}) \times \text{overall eff.}}{600000}$

"The product information specifications and descriptions contained in this catalog have been compiled for the use and convenience of our customers from information furnished by the manufacturer, and we cannot and do not accept any responsibility for the accuracy or correctness of any description, calculation, specification or information contained herein. No such description, calculated, specified or information regarding the products being sold has been made part of the basis of the bargain nor has same created or amounted to an express warranty that the products would conform thereto. **We are selling the goods and merchandise illustrated and described in this catalog on an as is basis and disclaim any implied warranty, including any warranty of merchantability or warranty of fitness for any particular purposes whatsoever, with respect to the goods and merchandise sold.** All manufacturer warranties shall be passed on to our customers, but we shall not be responsible for special, indirect, incidental or consequential damages resulting from the use of any of the products or information contained or described in the catalog."